



Manufacturer
TLV. CO., LTD.

Kakogawa, Japan
is approved by LRQA LTD. to ISO 9001/14001



Instruction Manual

Float Dynamic Steam Trap
JH15E • JH15M • JH15S

Copyright © 2015 by TLV CO., LTD.

All rights reserved

Contents

Introduction	1
Safety Considerations	2
Points to be Noted for Piping Installation	4
Principles of Operation	6
Specifications	7
Configuration	8
Installation	9
Operation	10
Maintenance.....	11
Operating the Air Vent Valve.....	13
Disassembly / Reassembly	15
Instructions for Plug / Holder Disassembly and Reassembly	18
Troubleshooting	19
Product Warranty	20

Introduction

Thank you for purchasing the **TLV** float dynamic steam trap.

This product has been thoroughly inspected before being shipped from the factory. When the product is delivered, before doing anything else, check the specifications and external appearance to make sure nothing is out of the ordinary. Also be sure to read this manual carefully before use and follow the instructions to be sure of using the product properly.

The JH15 steam trap is designed to automatically discharge condensate from the steam space. This trap is ideal for use on heaters or dryers or other steam equipment on applications where large quantities of condensate are generated.





If detailed instructions for special order specifications or options not contained in this manual are required, please contact **TLV** for full details.



This instruction manual is intended for use with the model(s) listed on the front cover. It is necessary not only for installation, but for subsequent maintenance, disassembly/reassembly and troubleshooting. Please keep it in a safe place for future reference.

Safety Considerations

- Read this section carefully before use and be sure to follow the instructions.
- Installation, inspection, maintenance, repairs, disassembly, adjustment and valve opening/closing should be carried out only by trained maintenance personnel.
- The precautions listed in this manual are designed to ensure safety and prevent equipment damage and personal injury. For situations that may occur as a result of erroneous handling, three different types of cautionary items are used to indicate the degree of urgency and the scale of potential damage and danger: DANGER, WARNING and CAUTION.
- The three types of cautionary items above are very important for safety: be sure to observe all of them as they relate to installation, use, maintenance, and repair. Furthermore, TLV accepts no responsibility for any accidents or damage occurring as a result of failure to observe these precautions.

Symbols

	Indicates a DANGER, WARNING or CAUTION item.
	Indicates an urgent situation which poses a threat of death or serious injury
	Indicates that there is a potential threat of death or serious injury
	Indicates that there is a possibility of injury or equipment / product damage

	NEVER apply direct heat to the float. The float may explode due to increased internal pressure, causing accidents leading to serious injury or damage to property and equipment.
	Install properly and DO NOT use this product outside the recommended operating pressure, temperature and other specification ranges. Improper use may result in such hazards as damage to the product or malfunctions that may lead to serious accidents. Local regulations may restrict the use of this product to below the conditions quoted.
	DO NOT use this product in excess of the maximum operating pressure differential. Such use could make discharge impossible (blocked).
	Use hoisting equipment for heavy objects (weighing approximately 20 kg (44 lb) or more). Failure to do so may result in back strain or other injury if the object should fall.
	Take measures to prevent people from coming into direct contact with product outlets. Failure to do so may result in burns or other injury from the discharge of fluids.

Safety considerations are continued on the next page.

 CAUTION	<p>When disassembling or removing the product, wait until the internal pressure equals atmospheric pressure and the surface of the product has cooled to room temperature.</p> <p>Disassembling or removing the product when it is hot or under pressure may lead to discharge of fluids, causing burns, other injuries or damage.</p>
	<p>Be sure to use only the recommended components when repairing the product, and NEVER attempt to modify the product in any way.</p> <p>Failure to observe these precautions may result in damage to the product and burns or other injury due to malfunction or the discharge of fluids.</p>
	<p>Use only under conditions in which no freeze-up will occur.</p> <p>Freezing may damage the product, leading to fluid discharge, which may cause burns or other injury.</p>
	<p>Use only under conditions in which no water hammer will occur.</p> <p>The impact of water hammer may damage the product, leading to fluid discharge, which may cause burns or other injury.</p>
	<p>Firmly secure piping immediately before and after the product.</p> <p>During operation (opening/closing of the main valve), discharging condensate and return flow may cause vibration (strong shocks), which could lead to severe pipeline shaking and even damage resulting in burns or other injury from the discharge of fluids.</p>

Points to be Noted for Piping Installation



Use only under conditions in which no water hammer will occur. The impact of water hammer may damage the product, leading to fluid discharge, which may cause burns or other injury.



Firmly secure piping immediately before and after the product. During operation (opening/closing of the main valve), discharging condensate and return flow may cause vibration (strong shocks), which could lead to severe pipeline shaking and even damage resulting in burns or other injury from the discharge of fluids.

Ensure that the pipes are connected as mentioned below so that the JH15 can be installed properly.

[Piping example and pipe-support locations]

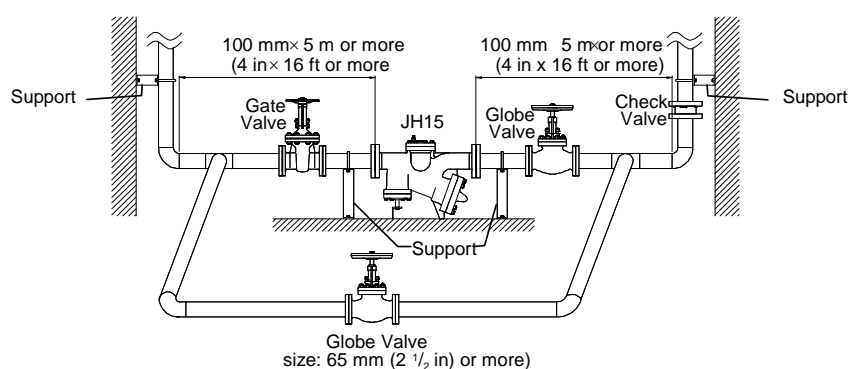

1. Horizontal piping with a nominal size of 100 mm (4 in) or more should be installed at trap inlet and outlet.
2. The trap should be installed horizontally. (The trap should be inclined no more than 5° horizontally and front-to-back.)
3. Sufficient space should be secured for maintenance and the piping should be securely supported.
4. Inlet and outlet valves to isolate the trap, and a bypass valve should be installed.
 - The valves before and after the trap should be full port type, or have an equivalent CV value to full port type.
 - Installation of a gate valve is recommended to ensure a smooth flow path at the trap inlet side. Though a gate valve is also recommended at the trap outlet side, a globe valve can be used instead. For the bypass valve, use a globe type valve with a nominal size of 65 mm (2¹/₂ in) or more.
5. A check valve should be installed at the trap outlet side. The check valve must be installed when there is any back pressure from collecting pipes, pipe rises, etc at outlet side.
6. The horizontal length of the inlet pipe should be as long as possible (5 m (16 ft) or more), with as few bends as possible, and installed so that the liquid will flow naturally down into the trap.
7. The straight horizontal length of the outlet pipe should also be long enough (5 m (16 ft) or more) without sharp bends.
8. A large enough pipe diameter for the outlet pipe should be selected so that the condensate velocity can be reduced as much as possible.
9. If the pipe length cannot be made 5 m (16 ft) or longer, ensure an internal pipe volume correspondent to a pipe diameter of 100 mm × 5 m (4 in × 16 ft) by

increasing the size of the pipe. (See the figure shown below.)

[NOTE: Equipping a larger pipe size by utilizing an eccentric reducer when it is difficult to install horizontal piping of 5 m (16 ft) or more]

[Relationship between the pipe length and pipe diameter before and after the product]

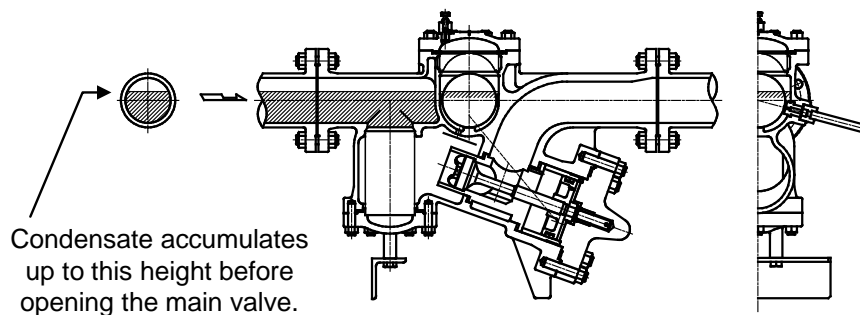
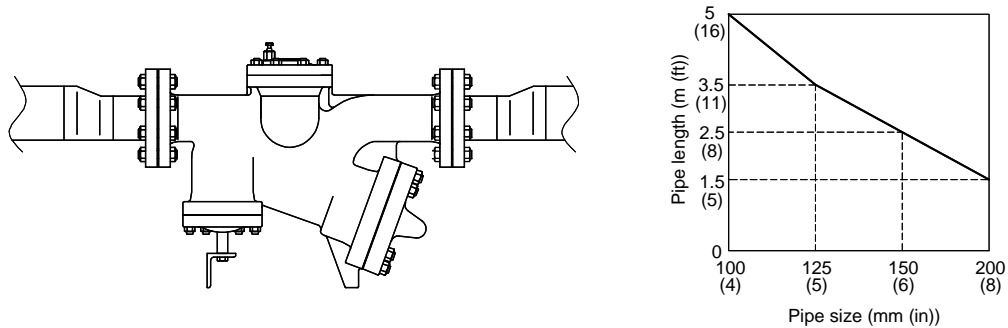

As the figure above shows, the inlet pipe operates as part of the main body for JH15 providing a place for condensate to accumulate. Where the products service life is concerned, a longer operation cycle is necessary, thus it is important to have a longer horizontal piping section. The longer the horizontal piping section is, the more condensate can be discharged in one cycle, and the longer it will take to discharge leading to a longer operation cycle. (Valve-open state: period of time when condensate is discharged, valve-closed state: period of time when condensate is being accumulated.)

As a large amount of condensate is discharged at once, vibrations (strong shocks) associated with operation occur. Therefore, the vibration (strong shocks) during operation can be reduced by ensuring a long enough horizontal portion of the outlet pipe. Also, safe and stable operation must be ensured by supporting the piping firmly.

Consult with TLV in case of difficulties with piping arrangement.

Principles of Operation

Valve Opens:

At start-up, air is discharged manually through operation of the air vent valve on the top of the cover.

When condensate flows into the trap, the float rises due to buoyancy and the condensate flows through the orifice into the cylinder, creating a secondary pressure there.

This secondary pressure pushes the piston up, opening the main valve and discharging the condensate that is inside the trap.

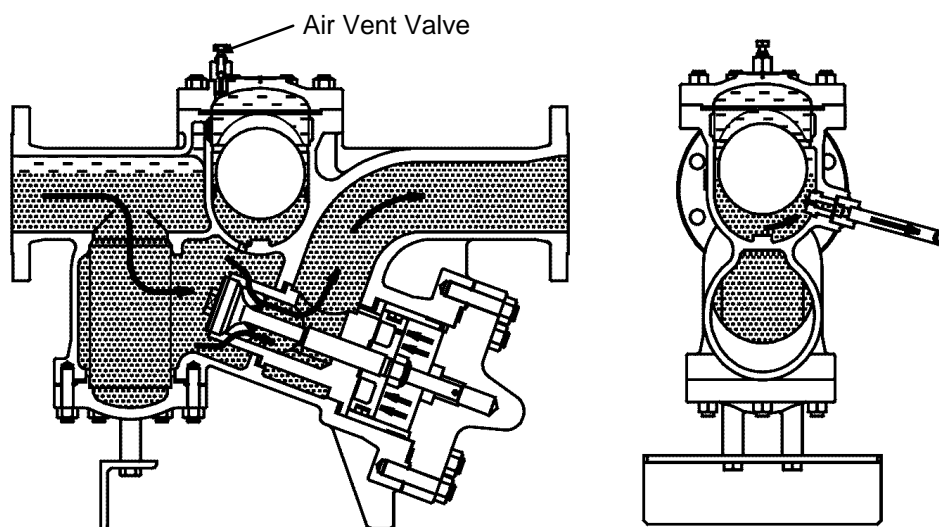

Valve Closes:

When condensate discharge is complete, the float falls, closing the orifice.

When this happens, the secondary pressure in the cylinder escapes to the outlet through the tiny holes in the piston, causing the inlet pressure to push the main valve back down and closed.

In this manner, condensate is intermittently discharged.

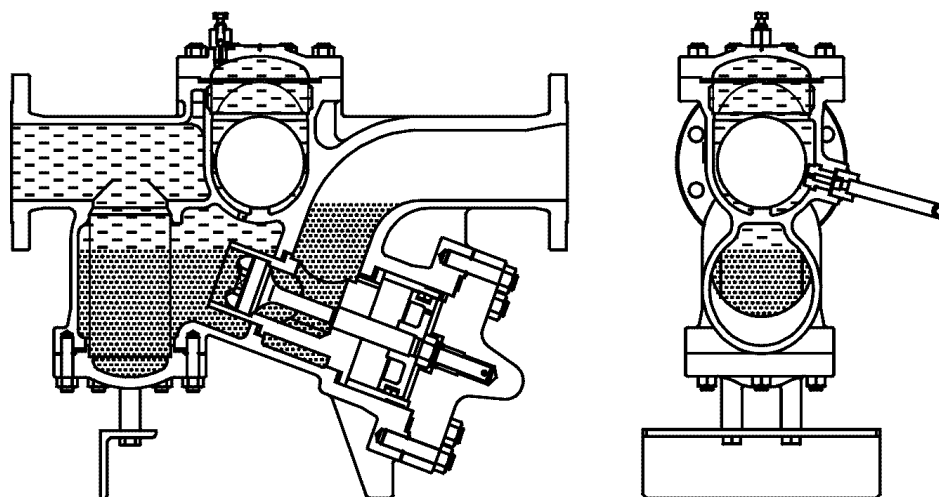

Specifications



Install properly and **DO NOT** use this product outside the recommended operating pressure, temperature and other specification ranges. Improper use may result in such hazards as damage to the product or malfunctions which may lead to serious accidents. Local regulations may restrict the use of this product to below the conditions quoted.



DO NOT use this product in excess of the maximum operating pressure differential; such use could make discharge impossible (blocked).



Use only under conditions in which no freeze-up will occur. Freezing may damage the product, leading to fluid discharge, which may cause burns or other injury.

Refer to the product nameplate for detailed specifications.

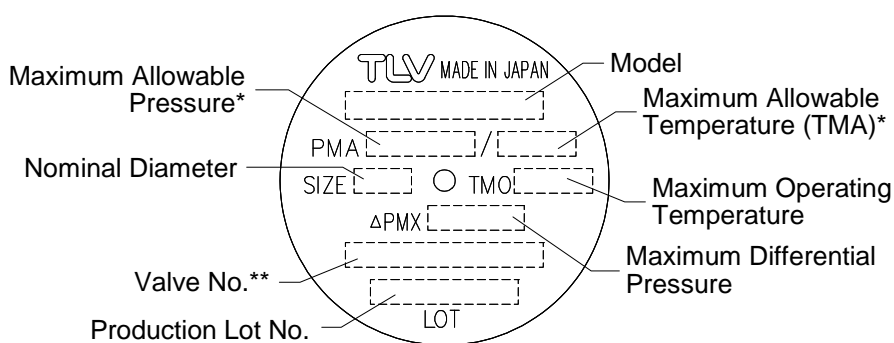

* Maximum allowable pressure (PMA) and maximum allowable temperature (TMA) are PRESSURE SHELL DESIGN CONDITIONS, **NOT** OPERATING CONDITIONS.

** Valve No. is displayed for products with options. This item is omitted from the nameplate when there are no options.

NOTE: The minimum differential pressure is 0.05 MPa (7 psi). Do not use this product with a differential pressure less than this.

Configuration

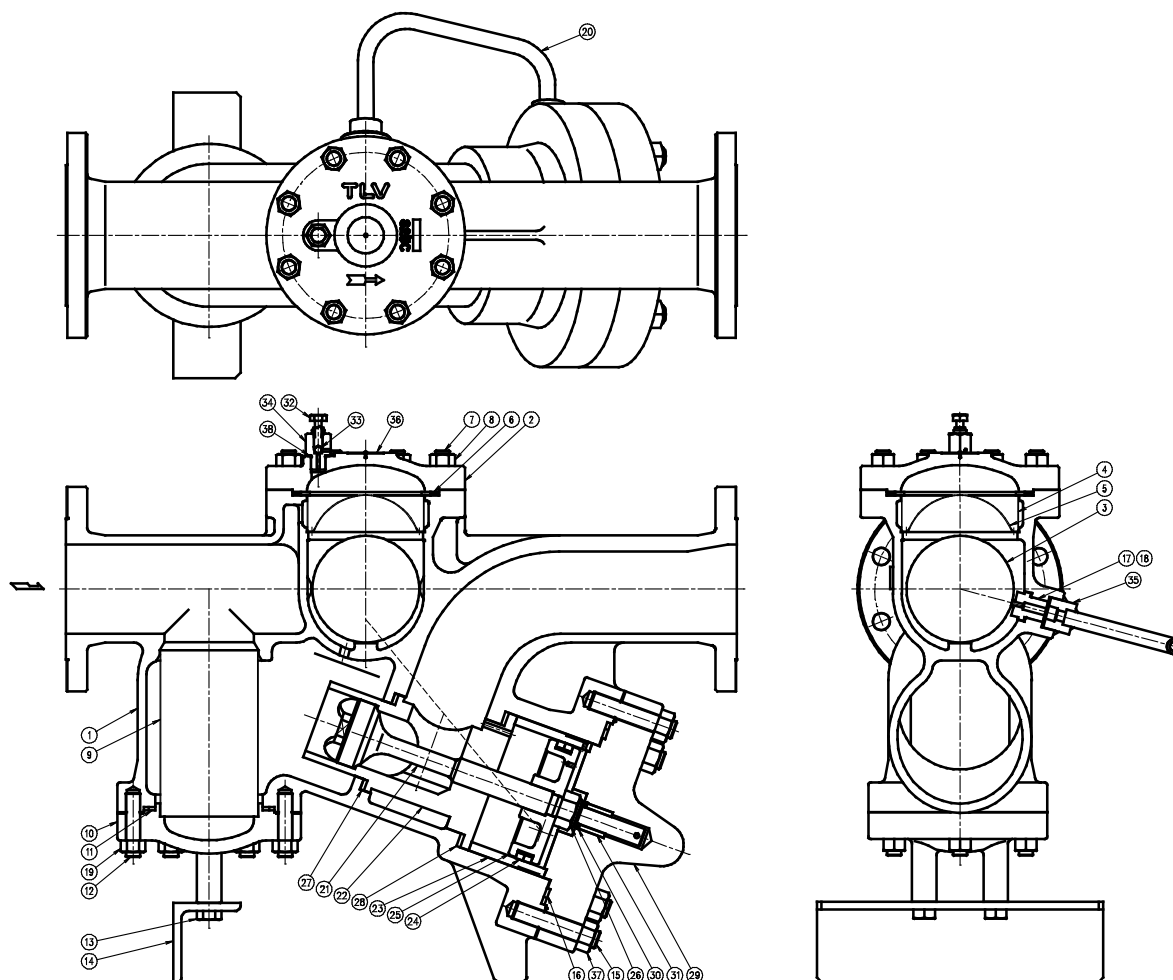

No.	Part Name	No.	Part Name	No.	Part Name
1	Body	14	Stand	27	Small Valve Seat Gasket
2	Cover	15	Valve Cover Bolt	28	Large Valve Seat Gasket
3	Float	16	Valve Cover Gasket	29	Valve Cover
4	Float Screen	17	Orifice	30	Snap Ring
5	Float Cover	18	Orifice Gasket	31	Sleeve
6	Cover Gasket	19	Screen Cover Nut	32	Air Vent Valve Stem
7	Cover Bolt	20	Connector Pipe	33	Steel Ball
8	Cover Nut	21	Main Valve	34	Air Vent Valve Body
9	Main Valve Screen	22	Valve Seat	35	Connector Pipe Socket
10	Screen Cover	23	Cylinder	36	Nameplate
11	Screen Cover Gasket	24	Piston Ring Set	37	Valve Cover Nut
12	Screen Cover Bolt	25	Piston	38	Air Vent Valve Gasket
13	Stand Bolt	26	U-Nut		

Installation



Install properly and **DO NOT** use this product outside the recommended operating pressure, temperature and other specification ranges. Improper use may result in such hazards as damage to the product or malfunctions which may lead to serious accidents. Local regulations may restrict the use of this product to below the conditions quoted.



Use hoisting equipment for heavy objects (weighing approximately 20 kg (44 lb) or more). Failure to do so may result in back strain or other injury if the object should fall.



Take measures to prevent people from coming into direct contact with product outlets. Failure to do so may result in burns or other injury from the discharge of fluids.



Firmly secure piping immediately before and after the product. During operation (opening/closing of the main valve), discharging condensate and return flow may cause vibration (strong shocks), which could lead to severe pipeline shaking and even damage resulting in burns or other injury from the discharge of fluids.

Installation, inspection, maintenance, repairs, disassembly, adjustment and valve opening/closing should be carried out only by trained maintenance personnel.

1. Before installation, be sure to remove all protective seals.
2. Before installing the product, open the inlet valve and blow out the piping to remove any piping scraps, dirt and oil. Close the inlet valve after blowdown.
3. Make sure the inlet valve (and outlet valve, if present) is closed before beginning installation.
4. Install the product so the arrow on the body is pointing in the direction of condensate flow.
5. Install the product into the piping in a manner that lets the condensate flow naturally down into the trap.
6. When the trap is operating (when the main valve is opening and closing), the discharging condensate and back flow may cause vibration (strong shocks). Therefore, the piping immediately before and after the trap, as well as further downstream, must be properly supported and secured.
7. Install inlet and outlet valves to isolate the trap and a bypass valve to discharge condensate from equipment and piping in the event of trap failure and when performing maintenance.
8. Secure sufficient space for inspection and maintenance.

If there is a problem, determine the cause using the “Troubleshooting” section in this manual.

Operation

1. For Start-up Operation

- (1) Just after the trap is installed or when it has been idle for a long period of time, be sure to blow out the rust and scale from the inside of the piping before opening the trap inlet valve.
- (2) After opening the outlet valve, slowly open the inlet valve, being very careful not to open it too suddenly. When this is done, the steam trap will begin operation automatically. It will shortly stabilize into normal operation.
- (3) Reconfirm the status of the trap operation (see the “Operational Check” section). If status is normal and stable, continue use with the valve open as it is.
- (4) When the trap will not be used for long periods of time, be sure to discharge any residual condensate to prevent the pipes from rusting.

2. Corrective Measures When a Malfunction Occurs

- (1) In the event of an abnormality, first carry out the following:
 - a) Close the inlet valve (and the outlet valve, if present).
 - b) Open the bypass valve and discharge the condensate from the equipment and pipes using the bypass.
- (2) Let the trap body cool thoroughly and, being careful of residual pressure and hot condensate, take the appropriate corrective measures in line with the remedial procedures described in the troubleshooting section.

Maintenance



Take measures to prevent people from coming into direct contact with product outlets. Failure to do so may result in burns or other injury from the discharge of fluids.



When disassembling or removing the product, wait until the internal pressure equals atmospheric pressure and the surface of the product has cooled to room temperature. Disassembling or removing the product when it is hot or under pressure may lead to discharge of fluids, causing burns, other injuries or damage.



Be sure to use only the recommended components when repairing the product, and NEVER attempt to modify the product in any way. Failure to observe these precautions may result in damage to the product or burns or other injury due to malfunction or the discharge of fluids.

Operational Check

A visual inspection of the following items should be done on a daily basis to determine whether the trap is operating properly or has failed. Periodically (at least biannually) the sound of operation and the trap surface temperature should also be checked by using diagnostic equipment, such as a stethoscope or thermometer.

A complete disassembly and inspection should be performed at least once every 3 years.

If the trap should fail, it may cause damage to piping and equipment, resulting in faulty or low quality products or losses due to steam leakage.

Normal:	Condensate is discharged intermittently and there is no leakage when the valve is closed. After the sound of the flow of condensate continues for some time, the sound of the valve closing on the valve seat can be heard. This is followed by an interval in which the trap makes no sound, after which the cycle is again repeated.
Blocked: (Discharge Impossible)	No condensate is discharged. The trap is quiet and makes no noise, and the surface temperature of the trap is low.
Blowing:	Live steam continually flows from the outlet and there is a continuous metallic sound.
Steam Leakage:	Live steam is discharged through the trap outlet together with condensate, accompanied by a high-pitched sound.

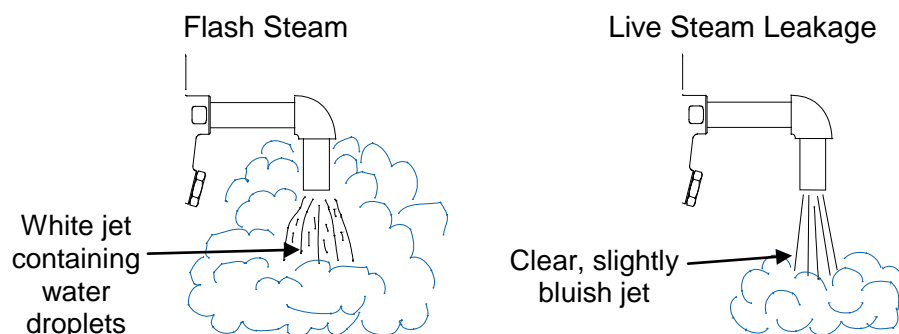

Parts Inspection

When parts have been removed, or during periodic inspections, use the following table to inspect the parts and replace any that are found to be defective.

Procedure	
Gaskets:	Check for warping and damage
Screen:	Check for warping, clogging and corrosion
Float:	Check for deformation, scratches and dents
Orifice:	Check for deformation, scratches and wear
Float Chamber:	Check for clogging of small holes
Piston, Cylinder:	Check for damage and wear
Main Valve, Valve Seat:	Check for wear of seating surfaces
Cylinder, Piston:	Check for wear of moving and rubbing parts
Sleeve:	Check for wear
Body Interior:	Check for the build-up of scale
Orifice Opening:	Check for dirt, oil film, wear and damage

Operating the Air Vent Valve



Be sure to use only the recommended components when repairing the product, and NEVER attempt to modify the product in any way. Failure to observe these precautions may result in damage to the product or burns or other injury due to malfunction or the discharge of fluids.

Installation, inspection, maintenance, repairs, disassembly, adjustment and valve opening/closing should be carried out only by trained maintenance personnel.

1. Locate the air vent valve exhaust port before operating the air vent valve, and take care to avoid being burned by hot air or steam blowing from the vent. The exhaust port is a 2 mm ($\frac{1}{16}$ in) diameter hole on the side of the air vent valve body.

DO NOT under any circumstances allow any unprotected part of your body to come in front of this hole.

2. Never leave an open air vent valve unattended.

Tools required: 1) open-end wrench (distance across flats 17 mm ($\frac{11}{16}$ in))

2) long-handled mirror to check for steam leakage after closing the exhaust port (leaking steam cloud the mirror)

- Using the open-end wrench, slowly turn the hexagonal head of the valve stem counterclockwise.
- Watch the exhaust port to determine the condition of the fluid discharged.

General guidelines:

Cloudy--water droplets and mist spraying out, indicating that air and condensate are being discharged

Clear----indicating that steam is being discharged; the valve port may now be closed

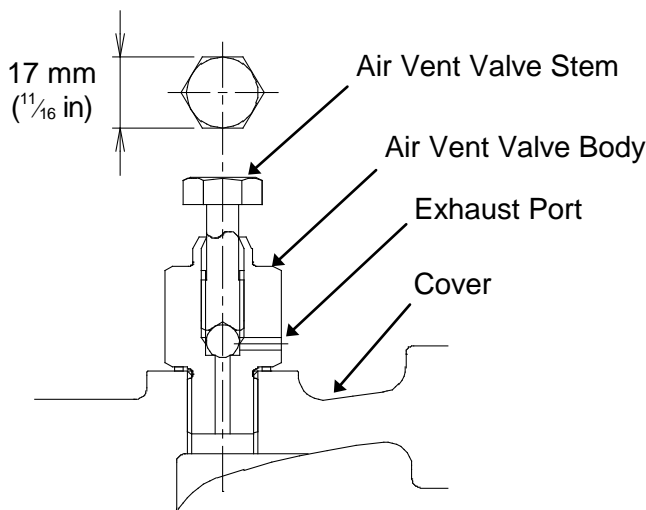

The air vent valve stem cannot be removed from the air vent valve body. Attempting to remove the valve by pulling it upward may damage it and cause burns or other injury due to malfunction or the discharge of steam or condensate.

3. Use the following procedure to close the valve and check for leaks:
 - Using the open-end wrench, close by slowly turning the hexagonal head of the valve stem clockwise until contact with the valve seat is felt.
 - Apply a little more pressure to tighten securely.
NOTE: Using an ordinary open-end wrench (handle length about 160 mm ($6\frac{1}{4}$ in)), the valve will close with only a light turn pressure. Tightening with too much force may result in seizure or damage to the seat.
 - After tightening, place the mirror close to the front of the exhaust port. If the mirror clouds, the valve is not fully closed; tighten a bit more.

4. When air enters the piping at start-up, it may accumulate inside the trap and hinder the flow of condensate (air binding). Air binding may also occur during the normal course of trap operation, due to the slow accumulation of air inside the trap. The air vent valve on the top of this trap is to be operated only when air binding has occurred. Follow the instructions in the earlier part of this section to operate the air vent valve and release the air accumulated inside the trap. (The air vent valve is to be open only for as long as is necessary to release the accumulated air. If left open, it is extremely dangerous, so be sure to close tightly after operation.)

Disassembly / Reassembly



WARNING

NEVER apply direct heat to the float. The float may explode due to increased internal pressure, causing accidents leading to serious injury or damage to property and equipment.



CAUTION

Use hoisting equipment for heavy objects (weighing approximately 20 kg (44 lb) or more). Failure to do so may result in back strain or other injury if the object should fall.



CAUTION

When disassembling or removing the product, wait until the internal pressure equals atmospheric pressure and the surface of the product has cooled to room temperature. Disassembling or removing the product when it is hot or under pressure may lead to discharge of fluids, causing burns, other injuries or damage.

Use the following procedures to remove components. Use the same procedures in reverse to reassemble.

(Installation, inspection, maintenance, repairs, disassembly, adjustment and valve opening/closing should be carried out only by trained maintenance personnel.)

Disassembly / Reassembly of the Orifice and its Components

Before removing the orifice and its components and disassembly / reassembly, make sure there is no residual pressure inside the product.

Part	During Disassembly	During Reassembly
Cover Nut	Use a socket wrench to remove the 8 nuts	Tighten evenly, being careful not to tighten one side more than the other; consult the table of tightening torques and tighten to the proper torque
Cover	Remove the cover	Make sure there are no pieces of the old gasket left on the sealing surfaces and then reattach
Cover Gasket	Remove the cover gasket	Replace with a new gasket; make sure there are no pieces of the old gasket left on the sealing surfaces of the body and then insert
Air Vent Valve Body	Remove with a wrench	Consult the table of tightening torques and tighten to the proper torque
Air Vent Valve Gasket	Remove the gasket	Replace with a new gasket; coat surfaces with anti-seize
Float Screen	Lift straight up and out while rocking gently	Place on the float cover, making sure that the top of the screen does not stick up out of the body
Float Cover	Remove without bending	Place on the ledge inside the body, making sure the rounded side is on top
Float	Remove, being careful not to scratch the polished surface	Insert, being careful not to scratch or misshape
Orifice	Remove with a socket wrench	Coat threads with anti-seize, consult the table of tightening torques and tighten to proper torque
Orifice Gasket	Remove the orifice gasket	Replace with a new gasket, coat sealing surfaces with anti-seize

Disassembly / Reassembly of the Valve and its Components

Part	During Disassembly	During Reassembly
Valve Cover Nut	Remove with a socket wrench	Tighten evenly, being careful not to tighten one side more than the other; consult the table of tightening torques and tighten to the proper torque
Valve Cover	Remove the cover	—
Valve Cover Gasket	Remove the gasket	Replace with a new gasket if warped or damaged
Main Valve Unit*	Remove from the body; first, remove the cylinder from the unit, then grasp the 2-sided portion of the main valve securely, loosen the U-nut and remove, being careful not to scratch the piston ring	Grasp the 2-sided portion of the main valve securely, consult the table of tightening torques for the U-nut torque and tighten to the proper torque; if the piston ring is worn or damaged, replace with a new piston ring set; when setting the cylinder and piston, be careful not to scratch the piston ring; be sure to insert the cylinder with the side with the 4 holes to the outside (toward the side cover) and on the top (if inserted with the opposite orientation, the trap will not operate); when inserting the piston into the cylinder, be sure to insert it with the holes in the piston on the same side as the exhaust holes in the valve seat; when inserting the main valve unit into the body, make sure to insert it with the exhaust holes facing upward
Valve Seat Gaskets	Remove the gaskets between the main valve unit and the body (2 sizes)	Replace with new gaskets; make sure there are no pieces of the old gaskets left on the sealing surfaces of the body and valve seat and then insert

* Main Valve Unit

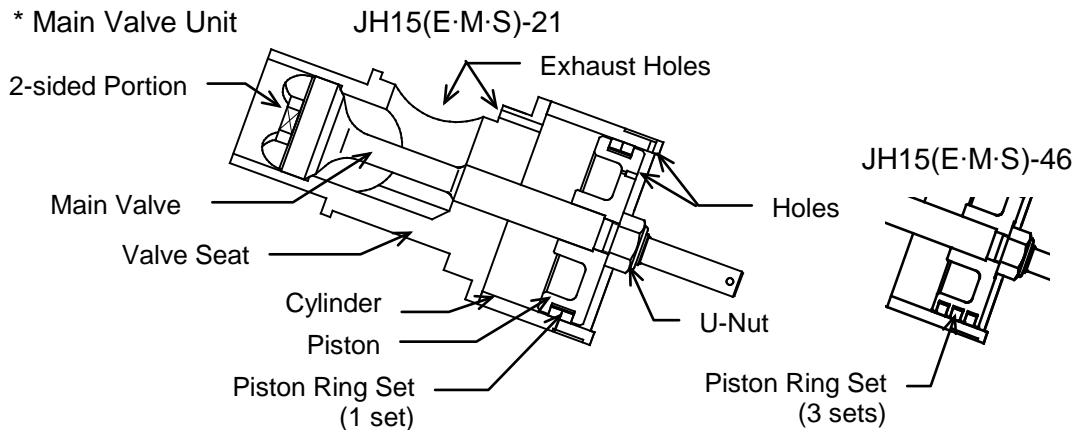

Disassembly / Reassembly of the Screen and its Components

Part	During Disassembly	During Reassembly
Stand Bolt	Remove with a wrench	Fasten securely
Screen Cover Nut	Offset the stand and remove the nut from the screen holder	Tighten evenly, being careful not to tighten one side more than the other
Screen Cover, Main Valve Screen	Remove the screen holder and take out the screen	Make sure there are no pieces of the old gasket left on the sealing surfaces; place screen on the screen cover and insert together into the body; consult the table of tightening torques and tighten nuts to the proper torque
Screen Cover Gasket	Remove the gasket	Replace with a new gasket; make sure there are no pieces of the old gasket left on the sealing surfaces of the body and then insert

Table of Tightening Torques

Part Name	Torque		Distance Across Flats	
	N·m	(ft·lb)	mm	(in)
Cover Nut	110	(81)	24	(1)
Valve Cover Nut	180	(130)	30	(1 ³ / ₁₆)
Screen Cover Nut	160	(115)	24	(1)
Air Vent Valve Body	100	(73)	24	(1)
Orifice	280	(210)	24	(1)
U-Nut for the Main Valve Unit	200	(150)	36	(1 ⁷ / ₁₆)

NOTE: - Coat all threaded portions with anti-seize. (1 N·m ≈ 10 kg·cm)
 - If drawings or other special documentation were supplied for the product, any torque given there takes precedence over values shown here.

Instructions for Plug / Holder Disassembly and Reassembly

The seal on the threaded plugs/holders found on TLV products is formed by a flat metal gasket. There are various installation orientations for the gaskets, such as horizontal, diagonal and downward, and the gasket may be pinched in the thread recesses during assembly.

Instructions for Disassembly and Reassembly

- ① Remove the plug/holder using a tool of the specified size (distance across flats).
- ② The gasket should not be reused. Be sure to replace it with a new gasket.
- ③ Clean the gasket surfaces of the plug/holder and the product body using a rag and/or cleaning agents, then check to make sure the surfaces are not scratched or deformed.
- ④ Coat both the gasket surface of the plug/holder and the threads of the plug/holder with anti-seize, then press the gasket onto the center of the gasket surface of the plug/holder, making sure the anti-seize affixes the gasket tightly to the plug/holder. Check to make sure the gasket is not caught in the recesses of the threads.

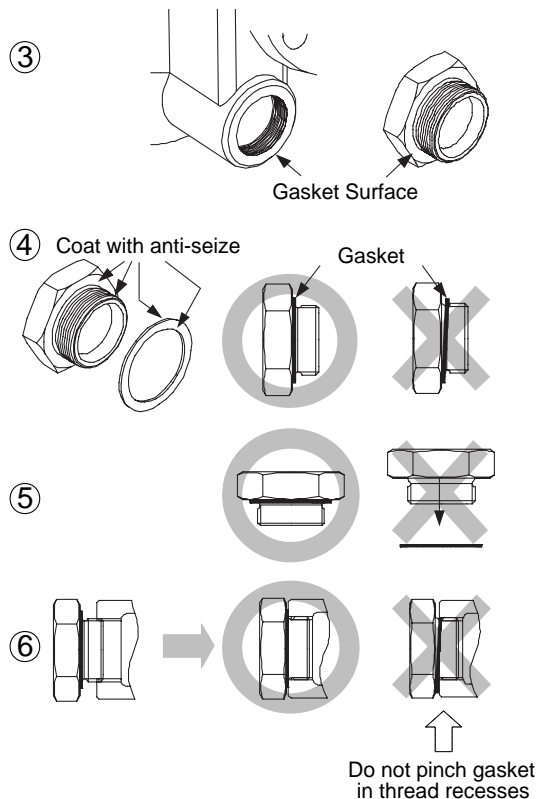

- ⑤ Hold the plug/holder upside down to make sure that the anti-seize makes the gasket stick to the plug/holder even when the plug/holder is held upside down.
- ⑥ Screw the plug/holder by hand into the product body while making sure that the gasket remains tightly affixed to the center of the gasket surface of the plug/holder. Make sure the entire gasket is making contact with the gasket surface of the product body. It is important at this point to make sure the gasket is not pinched in the thread recesses of the plug/holder.
- ⑦ Tighten the plug/holder to the proper torque.
- ⑧ Next, begin the supply of steam and check to make sure there is no leakage from the part just tightened. If there is leakage, immediately close the inlet valve and, if there is a bypass valve, take the necessary steps to release any residual pressure. After the surface of the product cools to room temperature, repeat the procedure beginning from step 1.

Troubleshooting



NEVER apply direct heat to the float. The float may explode due to increased internal pressure, causing accidents leading to serious injury or damage to property and equipment.



When disassembling or removing the product, wait until the internal pressure equals atmospheric pressure and the surface of the product has cooled to room temperature. Disassembling or removing the product when it is hot or under pressure may lead to discharge of fluids, causing burns, other injuries or damage.

If the product fails to operate properly, use the following table to locate the cause and remedy.

Problem	Cause	Remedy
No condensate is discharged (blocked) or discharge is poor	The float is damaged or filled with condensate	Replace with a new float
	There is no inflow of condensate	Inspect and correct the piping
	The orifice opening, screen or piping are clogged with rust and scale	Clean parts
	The trap operating pressure exceeds the maximum specified pressure or there is insufficient pressure differential between the trap inlet and outlet or there has been a drop in operating pressure	Compare specifications and actual operating conditions
	Air binding or steam locking has occurred	Operate the air vent valve, perform a bypass blowdown or close the trap inlet valve and allow the trap to cool
	The piston is damaged or the small holes in the piston have become enlarged	Replace with a new piston
	The piston has a build-up of sticky scale	Clean
	The cylinder is installed in an incorrect orientation	Reinstall the piston with the correct orientation
Steam is discharged or leaks from the outlet (blowing) (steam leakage)	The small holes in the piston have become clogged	Clean parts
	The main valve has a build-up of sticky scale	Clean
	The main valve, cylinder or orifice is worn	Replace with new parts as required
Steam is leaking from a place other than the outlet or exhaust	Gasket deterioration or damage	Replace with new gasket(s)
	Improper tightening torques were used	Tighten to the proper torque
Float is frequently damaged	Water hammer has occurred	Study and correct the piping

Product Warranty

1. Warranty Period
One year following product delivery.
2. Warranty Coverage
TLV CO., LTD. warrants this product to the original purchaser to be free from defective materials and workmanship. Under this warranty, the product will be repaired or replaced at our option, without charge for parts or labor.
3. This product warranty will not apply to cosmetic defects, nor to any product whose exterior has been damaged or defaced; nor does it apply in the following cases:
 - 1) Malfunctions due to improper installation, use, handling, etc., by other than TLV CO., LTD. authorized service representatives.
 - 2) Malfunctions due to dirt, scale, rust, etc.
 - 3) Malfunctions due to improper disassembly and reassembly, or inadequate inspection and maintenance by other than TLV CO., LTD. authorized service representatives.
 - 4) Malfunctions due to disasters or forces of nature.
 - 5) Accidents or malfunctions due to any other cause beyond the control of TLV CO., LTD.
4. Under no circumstances will TLV CO., LTD. be liable for consequential economic loss damage or consequential damage to property.

* * * * *

For Service or Technical Assistance:

Contact your **TLV** representative or your regional **TLV** office.

Manufacturer

TLV CO., LTD.
881 Nagasuna, Noguchi
Kakogawa, Hyogo 675-8511 JAPAN
Tel: 81-(0)79 - 427 - 1800