



Manufacturer

TLV CO., LTD.

Kakogawa, Japan

is approved by LRQA LTD. to ISO 9001/14001



Instruction Manual

Bypass Blowdown Steam Trap
(Free Float Steam Trap with X-element)
J3S-X-RV

Copyright © 2015 by TLV CO., LTD.

All rights reserved

Contents

Introduction	1
Safety Considerations	2
Checking the Piping	4
Operation	5
Specifications	6
Configuration	7
Installation	8
Maintenance.....	9
Operating Instructions for Regulation Valve.....	10
Disassembly/Reassembly	12
Instructions for Plug/Holder Disassembly and Reassembly ...	15
Troubleshooting	16
Product Warranty	17
Options.....	18

Introduction

Thank you for purchasing the **TLV** Bypass Blowdown Steam Trap (Free Float Steam Trap with X-element).

This product has been thoroughly inspected before being shipped from the factory. When the product is delivered, before doing anything else, check the specifications and external appearance to make sure nothing is out of the ordinary. Also be sure to read this manual carefully before use and follow the instructions to be sure of using the product properly.

This free float steam trap is of a revolutionary design that employs a high-performance X-element as an air vent. It is best suited for steam equipment use. The X-element is very sensitive to changes in temperature, and responds with great accuracy, allowing for the quick discharge of large quantities of initial air and cold condensate immediately after operation start-up, reducing start-up times. It also reacts with great sensitivity to the inflow of large quantities of condensate and hot air during operation, preventing air binding.

This steam trap, which combines the superior features of the X-element with the proven performance record of the free float, increases heating efficiency and reduces manpower requirements for maintenance and bypass blowdown.

The regulation valve incorporated into the cover makes bypass blow possible. In addition to discharging condensate and air produced on startup through the orifice and air vent valve, the regulation valve can be employed to increase condensate and air discharge for more rapid start-up. Also by adjusting the aperture of the regulation valve, it can be used to force steam discharge in order to solve problems with condensate drainage on cylinder dryers or equipment prone to condensate backup due to steam locking phenomenon.







If detailed instructions for special order specifications or options not contained in this manual are required, please contact **TLV** for full details.

This instruction manual is intended for use with the model(s) listed on the front cover. It is necessary not only for installation but for subsequent maintenance, disassembly/reassembly and troubleshooting. Please keep it in a safe place for future reference.

Safety Considerations

- Read this section carefully before use and be sure to follow the instructions.
- Installation, inspection, maintenance, repairs, disassembly, adjustment and valve opening/closing should be carried out only by trained maintenance personnel.
- The precautions listed in this manual are designed to ensure safety and prevent equipment damage and personal injury. For situations that may occur as a result of erroneous handling, three different types of cautionary items are used to indicate the degree of urgency and the scale of potential damage and danger: DANGER, WARNING and CAUTION.
- The three types of cautionary items above are very important for safety: be sure to observe all of them as they relate to installation, use, maintenance, and repair. Furthermore, TLV accepts no responsibility for any accidents or damage occurring as a result of failure to observe these precautions.

Symbols

	Indicates a DANGER, WARNING or CAUTION item.
	Indicates an urgent situation which poses a threat of death or serious injury
	Indicates that there is a potential threat of death or serious injury
	Indicates that there is a possibility of injury or equipment / product damage
	NEVER apply direct heat to the float. The float may explode due to increased internal pressure, causing accidents leading to serious injury or damage to property and equipment.
	Install properly and DO NOT use this product outside the recommended operating pressure, temperature and other specification ranges. Improper use may result in such hazards as damage to the product or malfunctions that may lead to serious accidents. Local regulations may restrict the use of this product to below the conditions quoted. DO NOT use this product in excess of the maximum operating pressure differential. Such use could make discharge impossible (blocked). Take measures to prevent people from coming into direct contact with product outlets. Failure to do so may result in burns or other injury from the discharge of fluids.

Safety considerations continued on next page

 CAUTION	<p>Use gloves when operating the regulation valve and keep all body parts well clear of the product. Failure to do so could result in burns, other injury or damage from the blowing of small amounts of steam and condensate.</p>
	<p>When disassembling or removing the product, wait until the internal pressure equals atmospheric pressure and the surface of the product has cooled to room temperature. Disassembling or removing the product when it is hot or under pressure may lead to discharge of fluids, causing burns, other injuries or damage.</p>
	<p>Be sure to use only the recommended components when repairing the product, and NEVER attempt to modify the product in any way. Failure to observe these precautions may result in damage to the product and burns or other injury due to malfunction or the discharge of fluids.</p>
	<p>Use only under conditions in which no freeze-up will occur. Freezing may damage the product, leading to fluid discharge, which may cause burns or other injury.</p>
	<p>Use only under conditions in which no water hammer will occur. The impact of water hammer may damage the product, leading to fluid discharge, which may cause burns or other injury.</p>

Checking the Piping



Use only under conditions in which no water hammer will occur. The impact of water hammer may damage the product, leading to fluid discharge, which may cause burns or other injury.

Check to make sure that the pipes to be connected to the trap have been installed properly.

1. Is the pipe diameter suitable?
2. Is the piping where the trap is to be installed horizontal?
3. Has sufficient space been secured for maintenance?
4. Have maintenance valves been installed at the inlet and outlet? If the outlet is subject to back pressure, has a check valve (TLV-CK) been installed?
5. Is the inlet pipe as short as possible, with as few bends as possible, and installed so the liquid will flow naturally down into the trap?
6. Has the piping work been done correctly, as shown in the figures below?

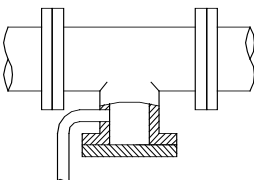
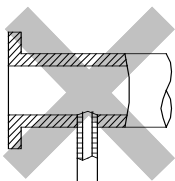
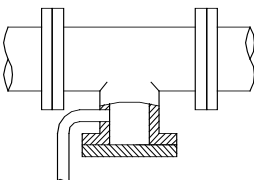
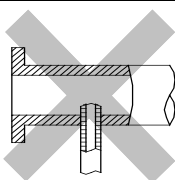
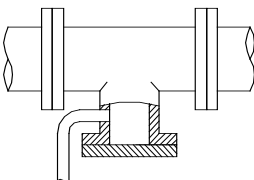
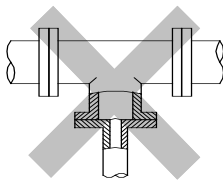
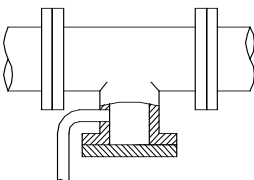
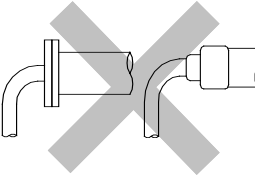
Requirement	Correct	Incorrect
Install catchpot with the proper diameter.		 Diameter is too small.
Make sure the flow of condensate is not obstructed.		 Diameter is too small and inlet protrudes into pipe interior.
To prevent rust and scale from flowing into the trap, the inlet pipe should be connected 25 – 50 mm (1 – 2 in) above the base of the T-pipe.		 Rust and scale flow into the trap with the condensate.
When installing on the blind end, make sure the flow of condensate is not obstructed.		 Condensate collects in the pipe.

Operation

Principles of air and condensate discharge:

1. Initial Air and Cold Condensate Discharge

At startup, before steam is supplied, the trap is cold so the X-element is contracted and the air vent valve seat (A) is open. This allows for the rapid discharge of air through the air vent valve (A) and cold condensate through the orifice (B), when steam is first supplied to the system.

Initial air/condensate can be discharged rapidly using the regulation valve as necessary.

Regulation valve: open

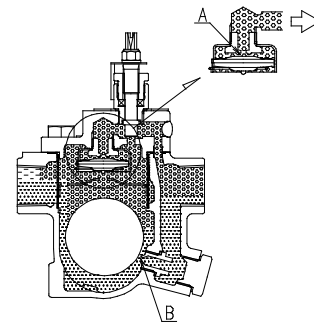

2. Condensate Discharge

After the discharge of initial air and cold condensate (regulation valve closed), the heat of the inflowing steam and condensate causes the X-element to expand, closing the air vent valve (A). The rising condensate level causes the float to rise due to buoyancy, opening the orifice (B) and allowing condensate to be discharged.

Regulation valve: closed

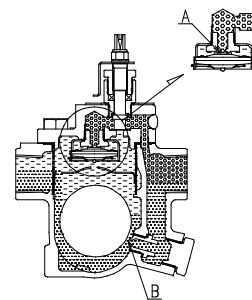

3. Hot Air Discharge

Should hot air flow into the trap with the steam during normal operation, the temperature of the X-element drops, causing it to momentarily contract and open the air vent valve (A), which allows for the rapid discharge of the air. After the air is discharged and steam contacts the X-element, the temperature will increase causing the air vent valve (A) to close.

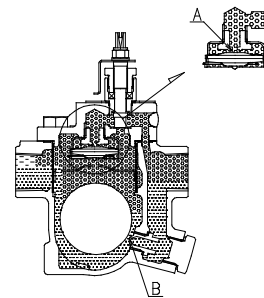

4. Closed Position

When the condensate flow rate decreases, the float falls as condensate is discharged, closing off the orifice (B). A water seal is maintained at all times over the orifice (B) to prevent steam loss.

NOTE: The high steam temperature causes the X-element to expand, keeping the air vent closed.

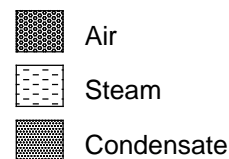
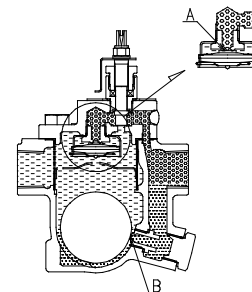

Specifications



Install properly and **DO NOT** use this product outside the recommended operating pressure, temperature and other specification ranges. Improper use may result in such hazards as damage to the product or malfunctions which may lead to serious accidents. Local regulations may restrict the use of this product to below the conditions quoted.



DO NOT use this product in excess of the maximum operating pressure differential; such use could make discharge impossible (blocked).



Use only under conditions in which no freeze-up will occur. Freezing may damage the product, leading to fluid discharge, which may cause burns or other injury.

Refer to the product nameplate for detailed specifications.

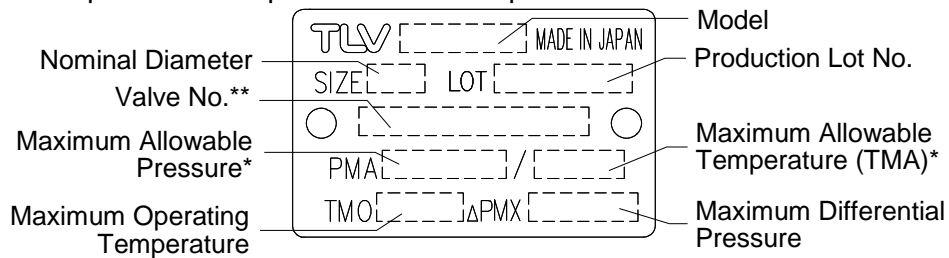

* Maximum allowable pressure (PMA) and maximum allowable temperature (TMA) are PRESSURE SHELL DESIGN CONDITIONS, **NOT** OPERATING CONDITIONS.

** Valve No. is displayed for products with options. This item is omitted from the nameplate when there are no options.

Configuration

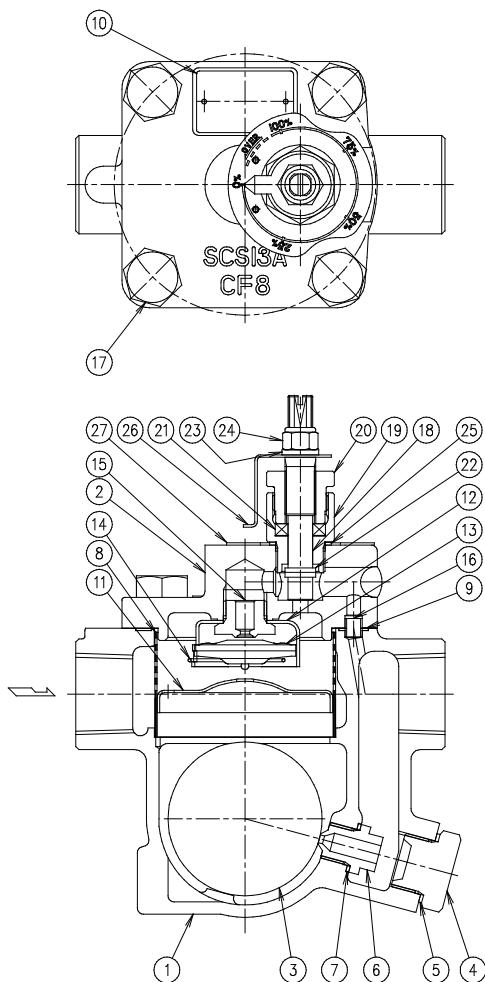

No.	Name	M*	R*	F*	V*
1	Body				
2	Cover				
3	Float			✓	
4	Orifice Plug				
5	Orifice Plug Gasket	✓	✓		
6	Orifice			✓	
7	Orifice Gasket	✓	✓		
8	Screen			✓	
9	Cover Gasket	✓	✓		
10	Nameplate				
11	Float Cover			✓	
12	X-element Guide			✓	
13	X-element			✓	
14	Spring Clip			✓	
15	Air Vent Valve Seat			✓	
16	Connector				
17	Cover Bolt				
18	Regulation Valve				✓
19	Gland Case				✓
20	Gland Retainer Nut				✓
21	Gland Packing				✓
22	Pin				✓
23	Washer				✓
24	Locknut				✓
25	Gland Case Gasket	✓	✓		✓
26	Aperture Indicator				✓
27	Aperture Indication Plate				

* Replacement parts are available only in the following kits:

M = Maintenance Kit R = Repair Kit
F = Float V = Regulation Valve Unit

Installation



Install properly and **DO NOT** use this product outside the recommended operating pressure, temperature and other specification ranges. Improper use may result in such hazards as damage to the product or malfunctions which may lead to serious accidents. Local regulations may restrict the use of this product to below the conditions quoted.



Take measures to prevent people from coming into direct contact with product outlets. Failure to do so may result in burns or other injury from the discharge of fluids.

Installation, inspection, maintenance, repairs, disassembly, adjustment and valve opening/closing should be carried out only by trained maintenance personnel.

1. Before installation, be sure to remove all protective seals.
2. Before installing the product, open the inlet valve and blow out the piping to remove any piping scraps, dirt and oil. Close the inlet valve after blowdown.
3. Install the product so the arrow on the body is pointing in the direction of flow.
4. The trap should be inclined no more than 5° horizontally and front-to-back.
5. Install a condensate outlet valve and outlet piping.
6. Open the inlet and outlet valves and ensure that the product functions properly.

If there is a problem, determine the cause using the “Troubleshooting” section in this manual.

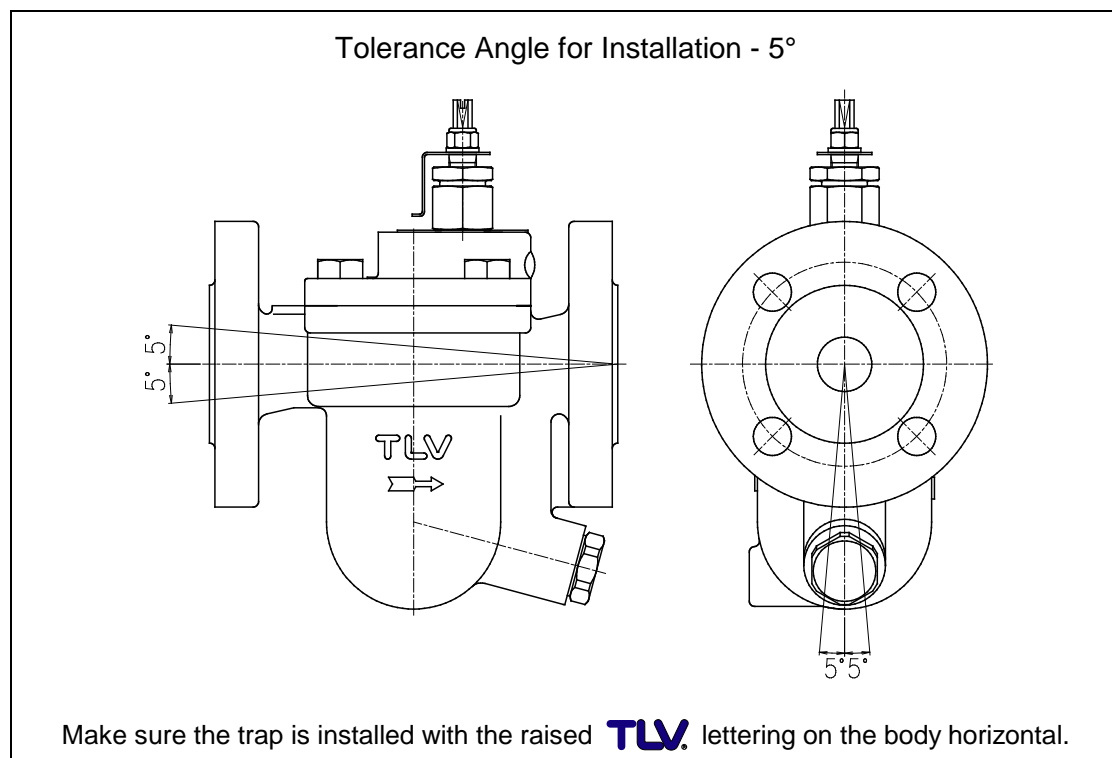

Maintenance



Take measures to prevent people from coming into direct contact with product outlets. Failure to do so may result in burns or other injury from the discharge of fluids.



Be sure to use only the recommended components when repairing the product, and NEVER attempt to modify the product in any way. Failure to observe these precautions may result in damage to the product or burns or other injury due to malfunction or the discharge of fluids.

Operational Check

Before carrying out a visual inspection, make sure that the regulation valve is closed. A visual inspection of the following items should be done on a daily basis to determine whether the trap is operating properly or has failed. Periodically (at least biannually) the operation should also be checked by using diagnostic equipment, such as a stethoscope, thermometer, TLV Pocket TrapMan or TLV TrapMan.

To confirm that the regulation valve is closed, make sure that the aperture indicator for the regulation valve points to "0%" on the aperture indication plate. If the valve cannot be fully closed, there is a problem. Refer to the "Troubleshooting" section to locate and remedy the cause.

If the trap or the regulation valve should fail, it may cause damage to piping and equipment, resulting in faulty or low quality products or losses due to steam leakage.

Normal:	Condensate is discharged continuously, together with flash steam, and the sound of flow can be heard. If there is very little condensate, there is almost no sound of flow.
Blocked: (Discharge Impossible)	No condensate is discharged. The trap is quiet and makes no noise, and the surface temperature of the trap is low.
Blowing:	Live steam continually flows from the outlet and there is a continuous metallic sound.
Steam Leakage:	Live steam is discharged through the trap outlet together with condensate, accompanied by a high-pitched sound.

(When conducting a visual inspection, flash steam is sometimes mistaken for steam leakage. For this reason, the use of a steam trap diagnostic instrument – such as TLV TrapMan – in conjunction with the visual inspection is highly recommended.)



Parts Inspection

When parts have been removed, or during periodic inspections, use the following table to inspect the parts and replace any that are found to be defective.

Procedure
Gaskets: check for warping or scratches
Screen: check for clogging or corrosion
X-element, Air Vent Valve Seat: check for scratches
Float: check for scratches or dents
Regulation Valve: check for scratches on the surface
Body Interior: check for build-up
Orifice Opening: check for dirt, oil film, wear or scratches

Operating Instructions for Regulation Valve



Use gloves when operating the regulation valve and keep all body parts well clear of the product. Failure to do so could result in burns, other injury or damage from the blowing of small amounts of steam and condensate.

Regulation Valve Unit

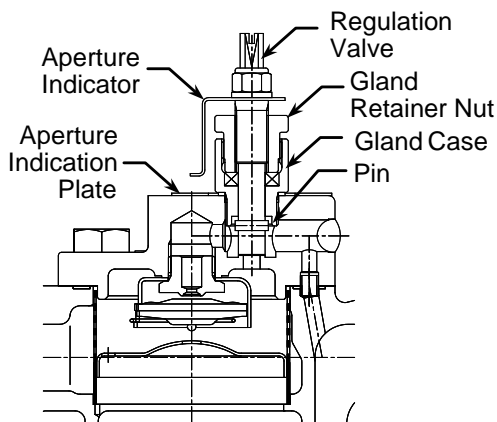

Steam Discharge Capacity Graph

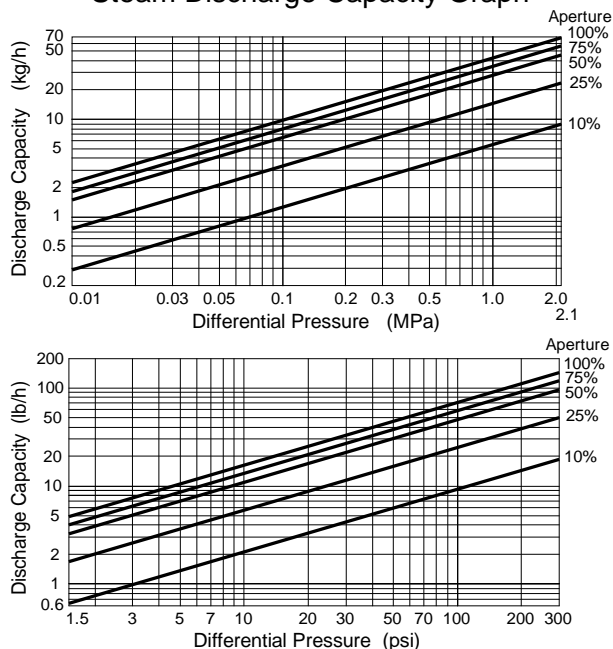

Operating Procedure

- When the product is shipped from the factory, the regulation valve is positioned in the lowest, valve-closed position.
 - Tools required (the regulation valve can be operated with any of the tools listed below):
 - Spanner (7 mm ($\frac{9}{32}$ in) across flats), adjustable wrench, flat-head screwdriver, handle (optional)
 - The following operating instruction is for the case that a spanner is used.
 - When operating the regulation valve, make sure to hold the hexagonal part of the gland case in place. (Use a part of the hexagonal section that does not touch the aperture indicator.)
 - When using the regulation valve for the bypass blowdown function (to shorten initial start-up time, etc.):
 - Use in a fully-opened position (aperture: 100%) at normal operation, then back to fully-closed position (aperture: 0%) once blowdown is complete.
 - When using the regulation valve to eliminate steam locking, etc.:
 - Reference the Steam Discharge Capacity graph and the percent open marking on the aperture indication plate to adjust the amount of steam blow.
- NOTE: When operating the regulation valve, make sure to use tools specified in step 2. Use the same tool for opening/closing the valve, as much as possible. If the valve is opened/closed with a spanner, adjustable wrench or a handle, it may be difficult to operate it with a flat-head screwdriver afterwards (as these tools are capable of tightening to a much higher

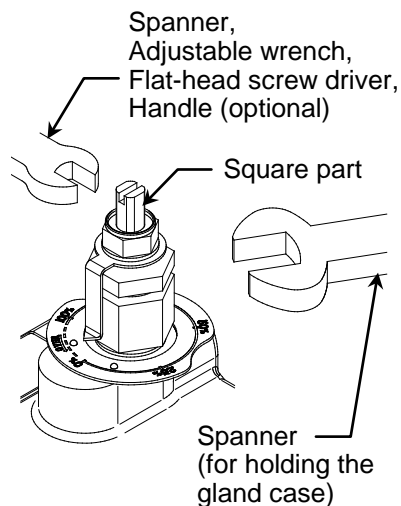

degree). In that case, use a spanner, adjustable wrench or handle. Do not turn the locknut, gland retainer nut, gland case, etc. while adjusting the regulation valve. Failure to do so could result in burns, other injury or damage from the blowing of small amounts of steam and condensate.

For opening the valve:

- Fit a spanner onto the the square part of the top of the regulation valve and turn slowly in the counterclockwise direction.

NOTE: Do not turn the regulation valve past the point at which it stops (where the internal pin contacts the gland case)

- The steam quantity can be adjusted by using the Steam Discharge Capacity Graph to find out what valve aperture corresponds to your desired steam discharge quantity and differential pressure, then using the valve aperture indication plate to set the valve aperture to the value taken from the graph.

For closing the valve:

- Fit a spanner onto the the square part of the very top of the regulation valve and turn slowly in the clockwise direction.
5. If steam should leak from the gland retainer nut or gland case, it can be stopped by further tightening the gland retainer nut. (Turn the regulation valve as far closed as it will go.)

Disassembly/Reassembly



WARNING

NEVER apply direct heat to the float. The float may explode due to increased internal pressure, causing accidents leading to serious injury or damage to property and equipment.



CAUTION

When disassembling or removing the product, wait until the internal pressure equals atmospheric pressure and the surface of the product has cooled to room temperature. Disassembling or removing the product when it is hot or under pressure may lead to discharge of fluids, causing burns, other injuries or damage.

Use the following procedures to remove components. Use the same procedures in reverse to reassemble.

(Installation, inspection, maintenance, repairs, disassembly, adjustment and valve opening/closing should be carried out only by trained maintenance personnel.)

Drain Plug (Option)

Part	During Disassembly	During Reassembly
Drain Plug	Remove with a socket wrench	Consult the table of tightening torques and tighten to the proper torque
Drain Plug Gasket	Remove the gasket	Replace with a new gasket; coat surfaces with anti-seize

Detaching/Reattaching the Cover

Part	During Disassembly	During Reassembly
Cover Bolt	Remove with a socket wrench	Consult the table of tightening torques and tighten to the proper torque
Cover	Remove by lifting up and off	Make sure there are no pieces of the old gasket left on the sealing surfaces of the body and cover, align the cover with the body and connector and reattach
Connector	Remove the connector	Reinsert into the hole in the body
Cover Gasket	Remove the gasket	Replace with a new gasket if misshapen or damaged

Disassembly/Reassembly of Components Inside the Cover

Part	During Disassembly	During Reassembly
Spring Clip	Pinch the insides together and remove from the X-element guide	Insert securely into the groove in the guide
X-element	Remove from the X-element guide	Insert after making sure it is in the correct orientation (Figure A)
Air Vent Valve Seat	Remove with a socket wrench	Consult the table of tightening torques and tighten to the proper torque
X-element Guide	Remove without bending	Fix with the air vent valve seat and make sure the X-element can be inserted smoothly

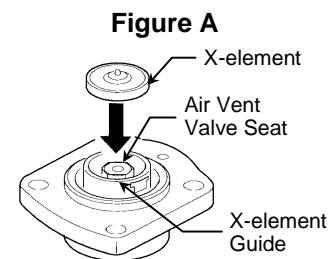

Detaching/Reattaching the Regulation Valve Unit

Part	During Disassembly	During Reassembly
Regulation Valve Unit*	Remove with a spanner (use spanner only on Gland Case section)	See "NOTE when assembling the unit" described below; consult the table of tightening torques and tighten to the proper torque
Gland Case Gasket		Replace with a new gasket; coat surfaces with anti-seize

*The regulation valve unit cannot be disassembled. It can only be detached/reattached as a unit.

NOTE: When assembling the unit:

When installing the regulation valve unit in the cover, make sure that the zero points of the aperture indicator and the aperture indication plate are aligned. If the zero points do not match up, they must be realigned.

Refer to the following steps for aligning the zero points:

1. Turn the regulation valve of the regulation valve unit counterclockwise and pull it up.
2. Loosen the locknut of the regulation valve.
3. Install the gland case gasket and the regulation valve unit in the cover (refer to the "Table of Tightening Torques").
4. Turn the regulation valve clockwise to close using the appropriate tool.
5. Turn the aperture indicator portion of the regulation valve unit until its point is aligned with the "0%" marking on the aperture indication plate. Once it is aligned with the marking, tighten the locknut.

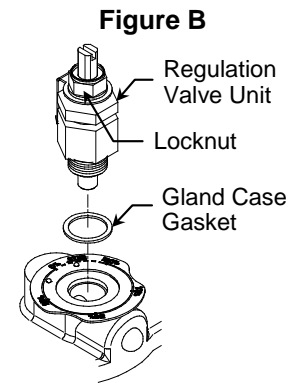

Disassembly/Reassembly of Components Inside the Body

Part	During Disassembly	During Reassembly
Float Cover & Screen	Lift straight up and out while rocking slowly	Align the arrows on the float cover/screen and the body, insert with the tab on the bottom fitting into the slot in the body; make sure the screen does not stick out of the body (Figure C)
Float	Remove, being careful not to scratch the surface	Insert, being careful not to scratch the surface
Orifice Plug	Remove with a socket wrench	Consult the table of tightening torques and tighten to the proper torque
Orifice Plug Gasket	Remove the gasket	Replace with a new gasket; coat surfaces with anti-seize
Orifice	Remove with a socket wrench	Consult the table of tightening torques and tighten to the proper torque
Orifice Gasket	Remove the gasket	Replace with a new gasket; coat surfaces with anti-seize

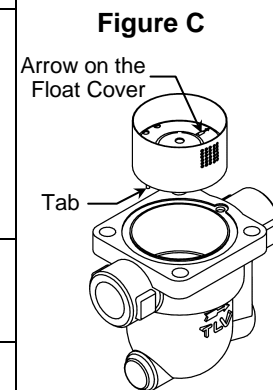

Table of Tightening Torques

	Torque		Distance Across Flats	
	N·m	(lbf·ft)	mm	(in)
Cover Bolt	50	(37)	17	(²¹ / ₃₂)
Air Vent Valve Seat	35	(26)	19	(³ / ₄)
Orifice Plug	80	(59)	24	(¹⁵ / ₁₆)
Orifice	30	(22)	10	(³ / ₈)
Gland Case	30	(22)	22	(⁷ / ₈)
Gland Retainer Nut	30	(22)	22	(⁷ / ₈)

(1 N·m ≈ 10 kg·cm)

NOTE: - Coat all threaded portions with anti-seize.
 - If drawings or other special documentation were supplied for the product, any torque given there takes precedence over values shown here.

Exploded View

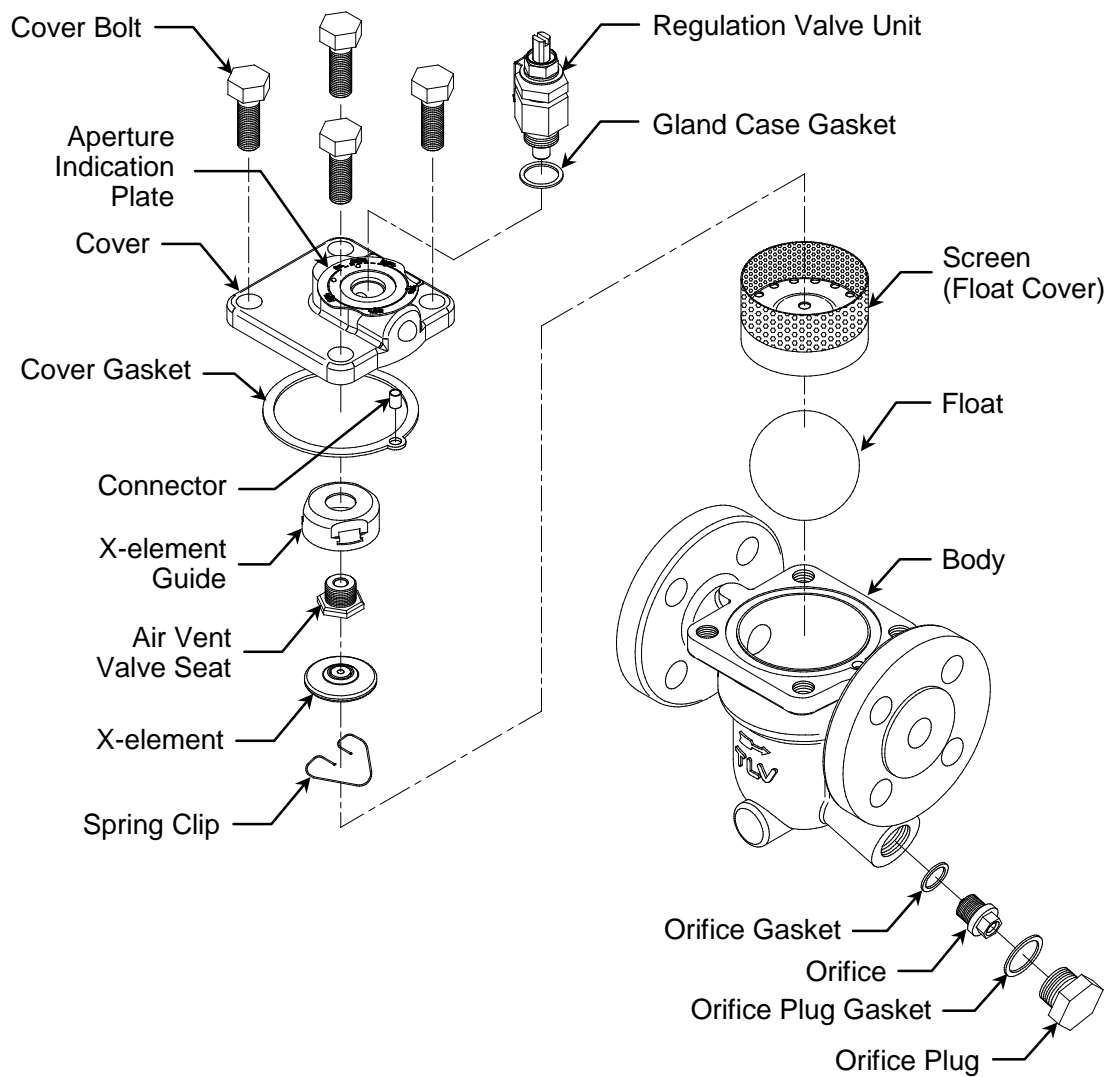

Instructions for Plug/Holder Disassembly and Reassembly

The seal on the threaded plugs/holders found on TLV products is formed by a flat metal gasket. There are various installation orientations for the gaskets, such as horizontal, diagonal and downward, and the gasket may be pinched in the thread recesses during assembly.

Instructions for Disassembly and Reassembly

- ① Remove the plug/holder using a tool of the specified size (distance across flats).
- ② The gasket should not be reused. Be sure to replace it with a new gasket.
- ③ Clean the gasket surfaces of the plug/holder and the product body using a rag and/or cleaning agents, then check to make sure the surfaces are not scratched or deformed.
- ④ Coat both the gasket surface of the plug/holder and the threads of the plug/holder with anti-seize, then press the gasket onto the center of the gasket surface of the plug/holder, making sure the anti-seize affixes the gasket tightly to the plug/holder. Check to make sure the gasket is not caught in the recesses of the threads.
- ⑤ Hold the plug/holder upside down to make sure that the anti-seize makes the gasket stick to the plug/holder even when the plug/holder is held upside down.
- ⑥ Screw the plug/holder by hand into the product body while making sure that the gasket remains tightly affixed to the center of the gasket surface of the plug/holder. Make sure the entire gasket is making contact with the gasket surface of the product body. It is important at this point to make sure the gasket is not pinched in the thread recesses of the plug/holder.
- ⑦ Tighten the plug/holder to the proper torque.
- ⑧ Next, begin the supply of steam and check to make sure there is no leakage from the part just tightened. If there is leakage, immediately close the inlet valve and, if there is a bypass valve, take the necessary steps to release any residual pressure. After the surface of the product cools to room temperature, repeat the procedure beginning from step ①.



Troubleshooting



WARNING

NEVER apply direct heat to the float. The float may explode due to increased internal pressure, causing accidents leading to serious injury or damage to property and equipment.



CAUTION

When disassembling or removing the product, wait until the internal pressure equals atmospheric pressure and the surface of the product has cooled to room temperature. Disassembling or removing the product when it is hot or under pressure may lead to discharge of fluids, causing burns, other injuries or damage.

If the product fails to operate properly, use the following table to locate and remedy the cause.

Problem	Cause	Remedy
No condensate is discharged (blocked) or discharge is poor	The float is damaged or filled with condensate	Replace with a new float
	The orifice opening, screen or piping are clogged with rust and scale	Clean parts
	The X-element is scratched or damaged	Replace with a new X-element
	The trap operating pressure exceeds the maximum specified pressure, or there is insufficient pressure differential between the trap inlet and outlet	Compare specifications and actual operating conditions
	Steam locking has occurred	Perform a bypass blowdown or close the trap inlet valve and allow the trap to cool
Steam is discharged or leaks from the outlet (blowing) (steam leakage)	Clogged orifice opening or regulation valve opening, or rust and scale build-up beneath the float	Clean parts
	Scratches on the orifice	Replace with a new orifice
	The float is misshapen or has surface build-up	Clean or replace with a new float
	Improper installation orientation	Correct the installation
	Trap vibration	Lengthen the inlet piping and fasten it securely
	The regulation valve is opened	Close the regulation valve
	The X-element and/or air vent valve seat have surface build-up or are scratched	Clean or replace with a new X-element/ air vent valve seat
Steam is blowing from the gland of the regulation valve	The gland retainer nut is loose	Re-tighten the gland retainer nut or replace with a new regulation valve unit
The regulation valve does not move	The regulation valve is clogged with rust and scale	Clean parts or replace with a new regulation valve unit
Steam is leaking from a place other than the outlet	Gasket deterioration or damage	Replace with new gasket(s)
	Improper tightening torques were used	Tighten to the proper torque
Float frequently becomes damaged	Water hammer has occurred	Study and correct the piping

NOTE: When replacing parts with new, use the parts list for reference, and replace with parts from the Maintenance kit, Repair kit, etc. Please note that replacement parts are only available as part of a replacement parts kit.

Product Warranty

1. Warranty Period
One year following product delivery.
2. Warranty Coverage
TLV CO., LTD. warrants this product to the original purchaser to be free from defective materials and workmanship. Under this warranty, the product will be repaired or replaced at our option, without charge for parts or labor.
3. This product warranty will not apply to cosmetic defects, nor to any product whose exterior has been damaged or defaced; nor does it apply in the following cases:
 - 1) Malfunctions due to improper installation, use, handling, etc., by other than TLV CO., LTD. authorized service representatives.
 - 2) Malfunctions due to dirt, scale, rust, etc.
 - 3) Malfunctions due to improper disassembly and reassembly, or inadequate inspection and maintenance by other than TLV CO., LTD. authorized service representatives.
 - 4) Malfunctions due to disasters or forces of nature.
 - 5) Accidents or malfunctions due to any other cause beyond the control of TLV CO., LTD.
4. Under no circumstances will TLV CO., LTD. be liable for consequential economic loss damage or consequential damage to property.

* * * * *

For Service or Technical Assistance:

Contact your **TLV** representative or your regional **TLV** office.

Manufacturer

TLV CO., LTD.
881 Nagasuna, Noguchi
Kakogawa, Hyogo 675-8511 JAPAN
Tel: 81-(0)79 - 427 - 1800

Options

The options shown below are available for this product on request. Please compare with the product you received.

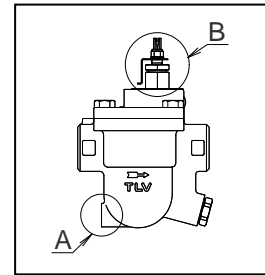

Options for Area A (standard: without drain plug)

With Drain Plug

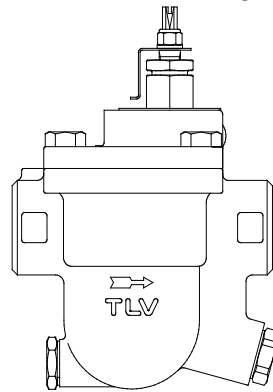

Torque		Distance Across Flats	
N·m	(lbf·ft)	mm	(in)
35	(26)	21	(¹³ / ₁₆)

(1 N·m ≈ 10 kg·cm)

Options for Area B (standard: without handle)

With Handle

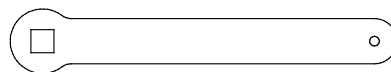

Length: 120 mm (4³/₄ in)

Distance Across Flats: 7 mm (⁹/₃₂ in)