



Manufacturer

**TLV** CO., LTD.

Kakogawa, Japan  
is approved by LRQA LTD. to ISO 9001/14001



# Instruction Manual

## **Pneumatic Direct-acting Pressure Reducing Valve for Steam and Air PN-DR**

## Contents

Introduction .....	1
Safety Considerations .....	2
Specifications .....	4
Acceptable Operating Range .....	4
Correct Usage of the PN-DR Direct-acting Pressure Reducing Valve	5
Configuration .....	7
Installation .....	8
Adjustment .....	11
Maintenance .....	12
Disassembly .....	13
Reassembly .....	16
Troubleshooting .....	17
Product Warranty .....	19

## Introduction

Thank you for purchasing the **TLV** PN-DR Pneumatic Direct-acting Pressure Reducing Valve for Steam and Air.

This product has been thoroughly inspected before being shipped from the factory. When the product is delivered, before doing anything else, check the specifications and external appearance to make sure nothing is out of the ordinary. Also be sure to read this manual carefully before use and follow the instructions to be sure of using the product properly.

The **TLV** PN-DR pneumatic direct-acting pressure reducing valve provides a more stable secondary pressure than conventional direct-acting reducing valves. The PN-DR is designed for a long service life, and is made of stainless steel for superior durability.

For products with special order specifications or options, if detailed instructions for the special order specifications or options are not contained in this manual, please contact **TLV** for full details.

This instruction manual is intended for use with the model(s) listed on the front cover. It is necessary not only for installation but for subsequent maintenance, disassembly/reassembly and troubleshooting. Please keep it in a safe place for future reference.

## Safety Considerations

- Read this section carefully before use and be sure to follow the instructions.
- Installation, inspection, maintenance, repairs, disassembly, adjustment and valve opening/closing should be carried out only by trained maintenance personnel.
- The precautions listed in this manual are designed to ensure safety and prevent equipment damage and personal injury. For situations that may occur as a result of erroneous handling, three different types of cautionary items are used to indicate the degree of urgency and the scale of potential damage and danger: DANGER, WARNING and CAUTION.
- The three types of cautionary items above are very important for safety: be sure to observe all of them as they relate to installation, use, maintenance, and repair. Furthermore, TLV accepts no responsibility for any accidents or damage occurring as a result of failure to observe these precautions.

### Symbols

	Indicates a <b>DANGER</b> , <b>WARNING</b> or <b>CAUTION</b> item.
	Indicates an urgent situation which poses a threat of death or serious injury
	Indicates that there is a potential threat of death or serious injury
	Indicates that there is a possibility of injury or equipment / product damage
	<p><b>Install properly and DO NOT use this product outside the recommended operating pressure, temperature and other specification ranges.</b> Improper use may result in such hazards as damage to the product or malfunctions that may lead to serious accidents. Local regulations may restrict the use of this product to below the conditions quoted.</p> <p><b>Take measures to prevent people from coming into direct contact with product outlets.</b> Failure to do so may result in burns or other injury from the discharge of fluids.</p> <p><b>When disassembling or removing the product, wait until the internal pressure equals atmospheric pressure and the surface of the product has cooled to room temperature.</b> Disassembling or removing the product when it is hot or under pressure may lead to discharge of fluids, causing burns, other injuries or damage.</p> <p><b>Be sure to use only the recommended components when repairing the product, and NEVER attempt to modify the product in any way.</b> Failure to observe these precautions may result in damage to the product and burns or other injury due to malfunction or the discharge of fluids.</p>

Safety considerations continued on next page.

 <b>CAUTION</b>	<b>Do not use excessive force when connecting threaded pipes to the product.</b>
	Over-tightening may cause breakage leading to fluid discharge, which may cause burns or other injury.
	<b>Use only under conditions in which no freeze-up will occur.</b> Freezing may damage the product, leading to fluid discharge, which may cause burns or other injury.
	<b>Use only under conditions in which no water hammer will occur.</b> The impact of water hammer may damage the product, leading to fluid discharge, which may cause burns or other injury.

## Specifications



Install properly and **DO NOT** use this product outside the recommended operating pressure, temperature and other specification ranges. Improper use may result in such hazards as damage to the product or malfunctions which may lead to serious accidents. Local regulations may restrict the use of this product to below the conditions quoted.



Use only under conditions in which no freeze-up will occur. Freezing may damage the product, leading to fluid discharge, which may cause burns or other injury.

Refer to the product nameplate for detailed specifications.

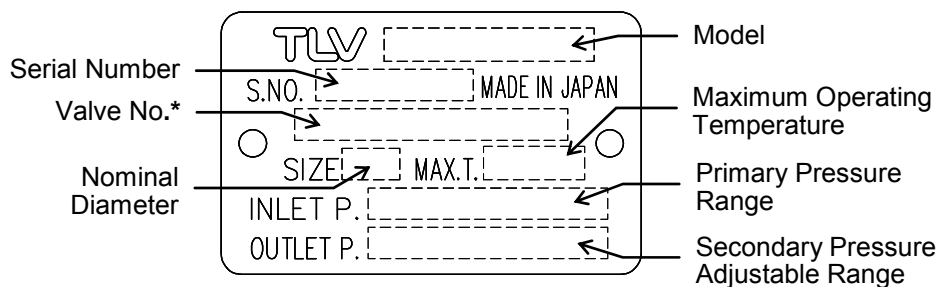

\* Valve No. is displayed for products with options. This item is omitted from the nameplate when there are no options.

## Acceptable Operating Range

Model	PN-DR-2	PN-DR-6
Primary Pressure Range	0.2 - 1.6 MPaG (30 – 230 psig)	
Adjustable Pressure Range	0.014 – 0.2 MPaG (2 – 30 psig) (but limited to $\frac{1}{30}$ of primary pressure)	0.18 - 0.6 MPaG (27 – 85 psig)
	Secondary pressure must not exceed 90% of primary pressure	
Maximum Operating Temperature	220 °C (428 °F)	
Motive Air Pressure	0 - 1.0 MPaG (0 – 150 psig) (Oil free air, filtered to 5 µm)	

## Correct Usage of the PN-DR Direct-acting Pressure Reducing Valve



Install properly and DO NOT use this product outside the recommended operating pressure, temperature and other specification ranges. Improper use may result in such hazards as damage to the product or malfunctions which may lead to serious accidents. Local regulations may restrict the use of this product to below the conditions quoted.

1. The PN-DR should be operated only within its specifications.
2. Installing an ON / OFF Valve (Solenoid Valve or Motorized Valve)

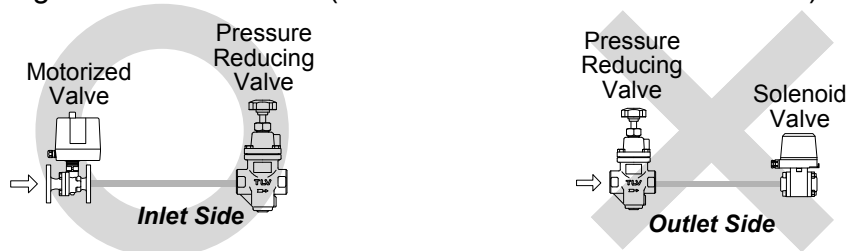

If an on-off valve is required to stop supply of steam or air to the equipment, install it at the inlet side of the PN-DR.

If a solenoid valve is installed at the outlet of the PN-DR, it will cause heavy chattering and may lead to damage of the PN-DR. (When the on-off valve opens, the secondary pressure of the reducing valve changes from zero to the set pressure. Passing through an area of the reducing ratio of less than 30:1 where adjustment is impossible, chattering occurs momentarily.) To save energy, install the on-off valve as near to the boiler, or compressor, as possible.

NOTE: To prevent water hammer, it is recommended that a slow-acting motorized on-off valve be used. If a fast-acting solenoid valve is used, the potential water hammer effect can damage the equipment and the pressure reducing valve.

3. Installing a Control and/or Safety Valve

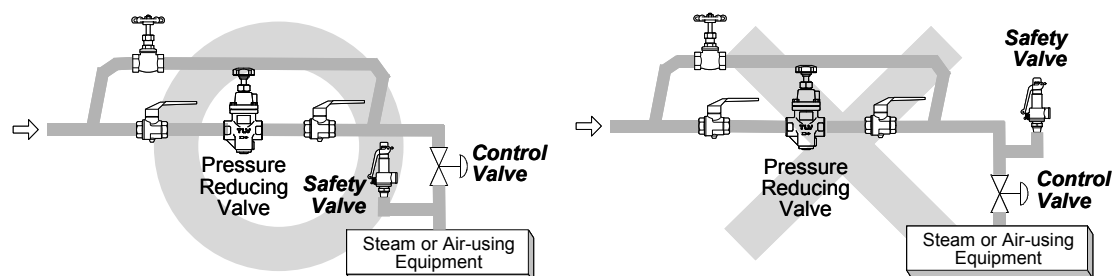

A control valve (i.e. for temperature control) installed between the PN-DR and the equipment (downstream of the reducing valve) may raise the pressure between the PN-DR and the control valve when the control valve is closed, depending on the spatial relationship. Therefore, this valve should be installed close to the equipment, as illustrated. Also, a safety valve should be installed downstream of the control valve.

NOTE: When installing a safety valve to protect steam or air equipment, be sure to install it on, or directly before the inlet, of the equipment. If the safety valve is installed between the PN-DR and a control valve, an eventual pressure rise could activate the safety valve.

4. Precautions for the Installation of Additional Fittings Before or After the PN-DR  
 In order to ensure a stable flow of air or steam, the piping upstream and downstream of the reducing valve must be straight runs. If a pressure reducing valve is installed either directly before or after an elbow or control valve, unevenness in flow may result in chattering and unstable pressure. To ensure a stable flow, it is recommended that the pressure reducing valve be installed on straight runs of piping, as illustrated below.

① Inlet (primary side) of the pressure reducing valve

Maintain a straight piping run of **10 d or more** when a manual valve, a strainer or an elbow, etc. is installed.  
 (Example: if nominal size is 25 mm (1 in), have 250 mm (10 in) or more)

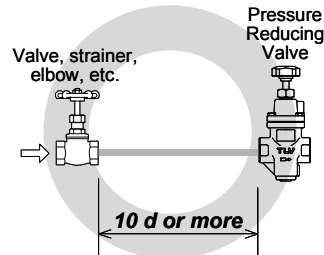

NOTE: d = pipe diameter

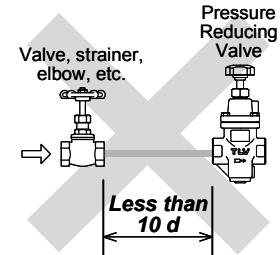

Maintain a straight piping run of **30 d or more** when an automated valve (on-off valve) is installed.  
 (Example: if nominal size is 25 mm (1 in), have 750 mm (30 in) or more)

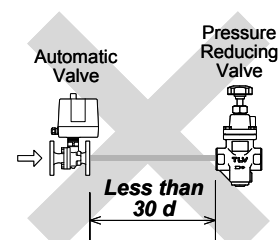
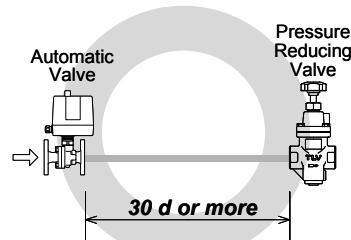

② Outlet (secondary side) of the pressure reducing valve

Maintain a straight piping run of **15 d or more** when a manual valve, a strainer or an elbow, etc. is installed.  
 (Example: if nominal size is 25 mm (1 in), have 375 mm (15 in) or more)

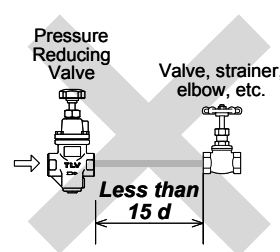
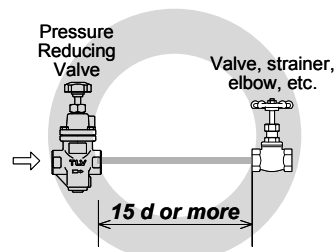

Maintain a straight piping run of **30 d or more** when a safety valve is installed.  
 (Example: if nominal size is 25 mm (1 in), have 750 mm (30 in) or more)

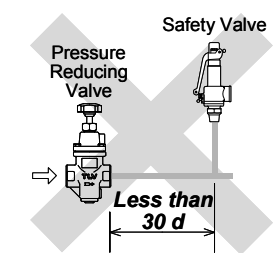
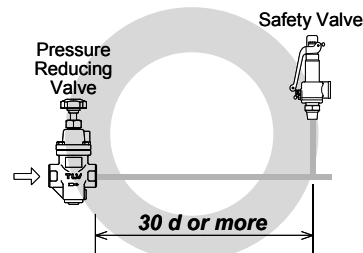

Maintain a straight piping run of **30 d or more** when another pressure reducing valve is installed. (Two-stage pressure reduction)  
 (Example: if nominal size is 25 mm (1 in), have 750 mm (30 in) or more)

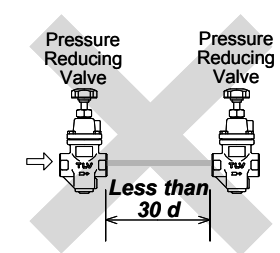
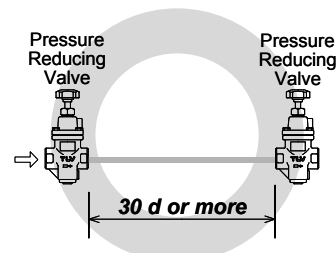

## Configuration

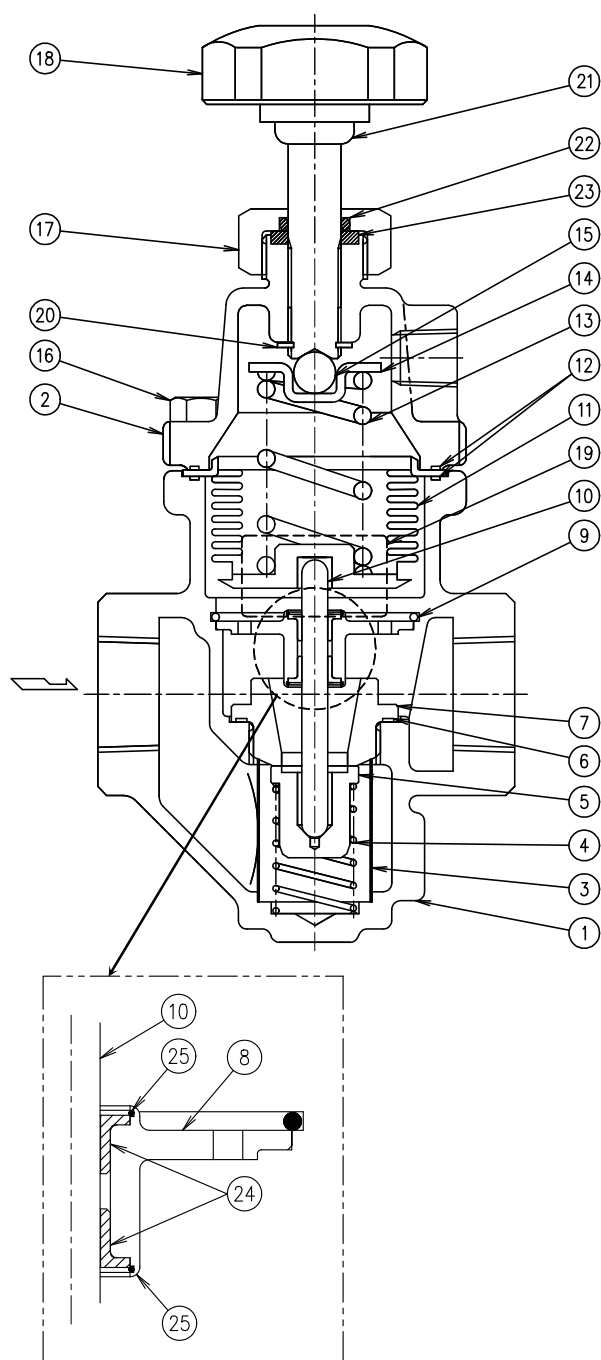

No.	Name	A* <sup>1</sup>	B* <sup>1</sup>	C* <sup>1</sup>	D* <sup>1</sup>	E* <sup>1</sup>
1	Body					
2	Cover					
3	Screen			✓		
4	Coil Spring			✓		
5	Main Valve			✓		
6	Valve Seat Gasket	✓		✓		
7	Valve Seat			✓		
8	Spacer* <sup>3</sup>		✓			
9	Snap Ring					
10	Valve Stem		✓			
11	Bellows				✓	
12	Cover Gasket* <sup>2</sup>	✓	✓	✓	✓	✓
13	Coil Spring					
14	Spring Guide					
15	Steel Ball					
16	Cover Bolt					
17	Holder Nut					
18	Adjustment Handle					✓
19	Nameplate					
20	Retaining Ring					✓
21	Retainer					✓
22	Seal Ring	✓				✓
23	Packing	✓				✓
24	Slide Bearing* <sup>2</sup> * <sup>3</sup>		✓			
25	Snap Ring* <sup>2</sup> * <sup>3</sup>		✓			

\*<sup>1</sup>Replacement parts are available only in the following kits:

- A: Maintenance Kit
- B: Repair Kit for Spacer
- C: Repair Kit for Main Valve,
- D: Repair Kit for Bellows
- E: Repair Kit for Adjustment Handle

\*<sup>2</sup>Number of parts: 2 pieces

\*<sup>3</sup>Shipped as a unit



## Installation



Install properly and **DO NOT** use this product outside the recommended operating pressure, temperature and other specification ranges. Improper use may result in such hazards as damage to the product or malfunctions which may lead to serious accidents. Local regulations may restrict the use of this product to below the conditions quoted.



Take measures to prevent people from coming into direct contact with product outlets. Failure to do so may result in burns or other injury from the discharge of fluids.

Installation, inspection, maintenance, repairs, disassembly, adjustment and valve opening/closing should be carried out only by trained maintenance personnel.

### 1. Blowdown

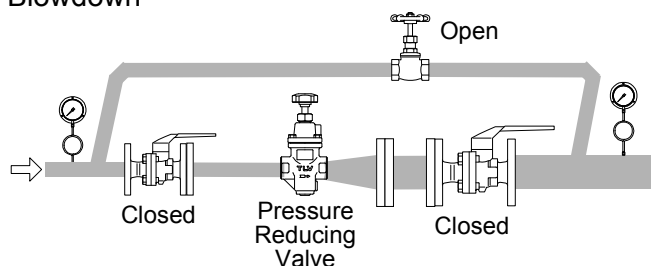

Blowdown using a bypass line

Before installing the PN-DR unit, be sure to blow down all piping thoroughly. If this is not possible, perform a blowdown using the bypass valve. Blowdown is especially important for newly installed piping or after the system has been shut down for a long period of time.

### 2. Removing the Protective Caps

Before installation, be sure to remove all protective seals and caps. (Found in 3 locations; on the product inlet and outlet, motive air connecting port.)

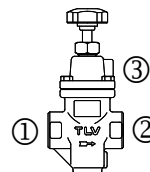

### 3. Tolerance Angle for Installation

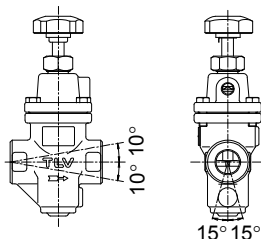

Make sure the PN-DR is installed on horizontal piping with the adjustment handle facing up. Ensure the raised TLV lettering on the body is horizontal and the arrow is pointing in the direction of flow. The allowable inclination of the PN-DR is 10° front-to-back and 15° horizontally.

### 4. Piping Support

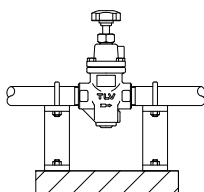

Pay attention to avoid excessive load, bending and vibration. Supporting the inlet and outlet pipes securely is recommended.

### 5. Maintenance Space

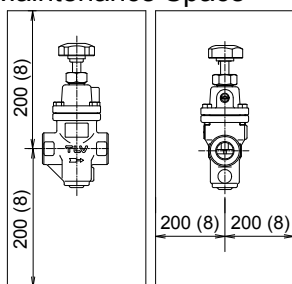

Leave sufficient space for maintenance, inspection and repair.  
Unit: mm (in)

### 6. Piping Size

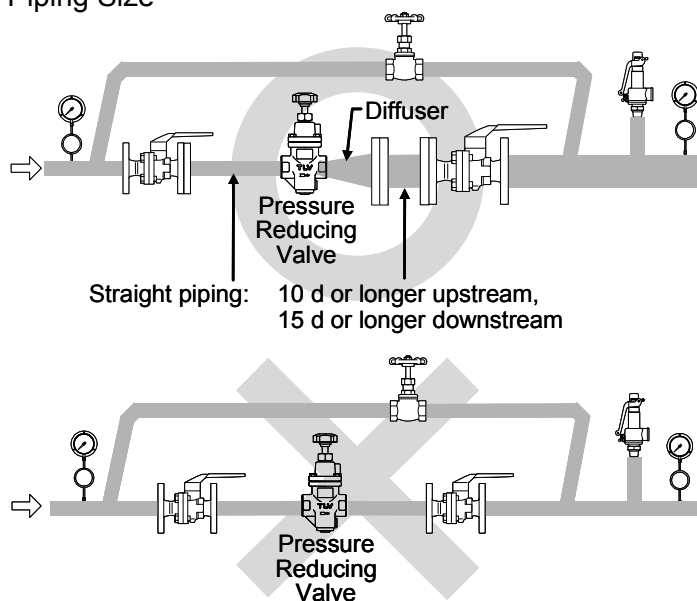

If it is expected that the secondary flow velocity will be more than 30m/s (100 ft/s), install a diffuser in order to keep the flow velocity below 30m/s(100 ft/s). If the distance between the reducing valve and the equipment is great, a possible drop in pressure should be taken into consideration when selecting the piping size. If installing a strainer, horizontal installation is recommended in order to prevent pooling of condensate.

### 7. Two-stage Pressure Reduction

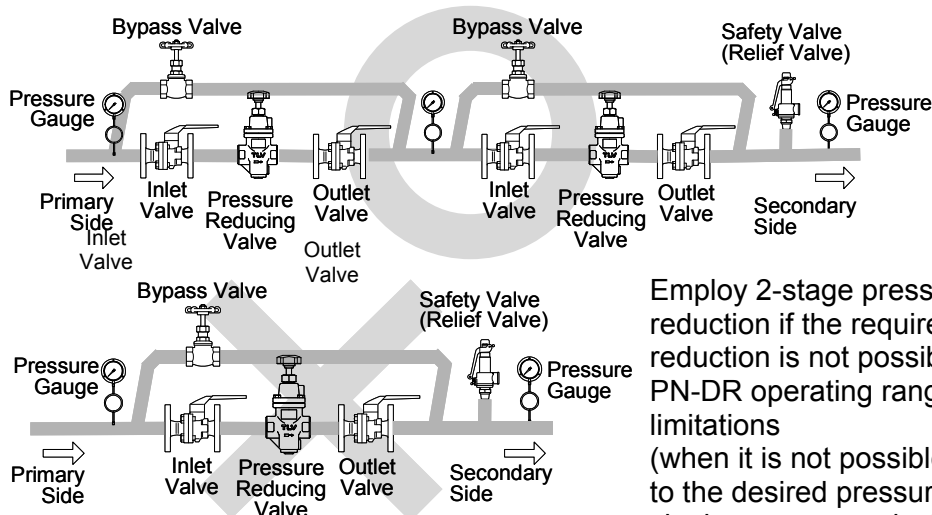

Employ 2-stage pressure reduction if the required reduction is not possible due to PN-DR operating range limitations (when it is not possible to reduce to the desired pressure using a single pressure reducing valve).

## 8. Valves and Accessories

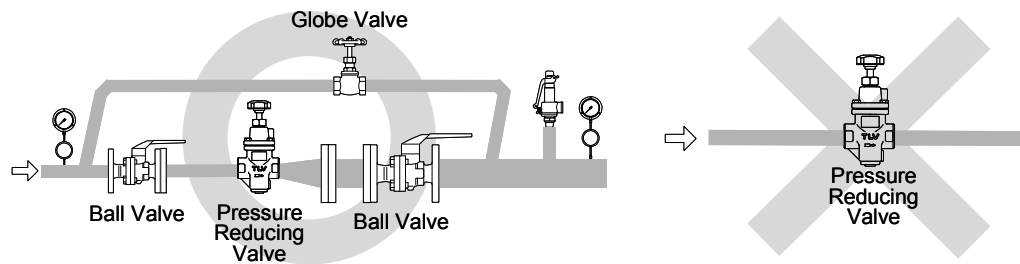

Always install a bypass line. At the inlet and outlet, install a pressure gauge and a shut-off valve. Ball valves, which will not retain condensate, are recommended for inlet/outlet shut-off valves. The nominal pipe size for the bypass line should be  $\frac{1}{2}$  or greater of the primary pipe size.

## 9. Motive Air

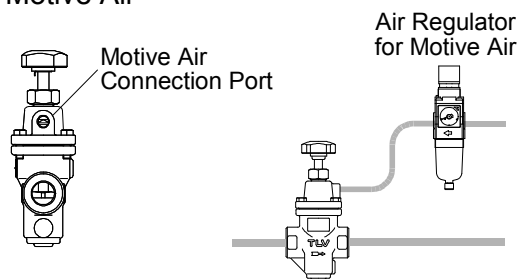

Supply oil free air filtered to  $5\ \mu\text{m}$  for the motive air and adjust the air pressure to match desired value by using an air regulator or similar device.

## Adjustment

The PN-DR can set secondary pressure(s) either by operation of the adjustment handle or adjustment of the motive air pressure, or a combination of both.

To avoid problems such as water hammer and to protect steam and air equipment, the PN-DR reducing valve should be correctly adjusted.

1. It is necessary to blow down all pipe lines thoroughly.  
The blowdown is especially important if the line is new or has been shut down for a long period of time. Take particular care to ensure that matter such as condensate and dirt does not remain inside the equipment.  
(Stay clear of any pressurized blow-out from the safety valve.)

2. Make sure that the shut-off and bypass valves located upstream and downstream of the PN-DR are completely closed.

3. Turn the adjustment handle counterclockwise to free the coil spring.

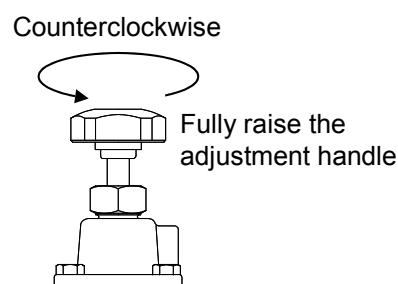

4. Slowly, fully open the shut-off valve at the inlet of the PN-DR.
5. Slightly open the shut-off valve at the outlet of the PN-DR.
6. Slowly turn the adjustment handle clockwise until the desired secondary (steam or air) pressure is obtained with the pressure of the coil spring. Wait several minutes. Be careful not to make rapid adjustments as the safety valve may be activated or equipment may be damaged by water hammer.

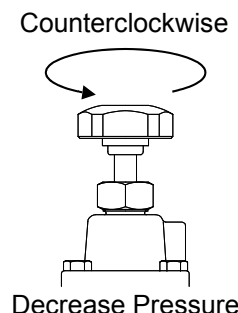
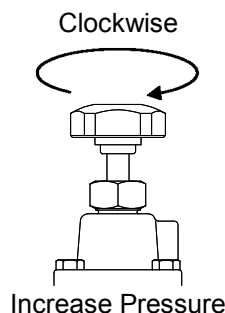

7. Adjust the motive air pressure until the desired secondary (steam or air) pressure is obtained. Wait several minutes. Be careful not to make rapid adjustments as the safety valve may be activated or equipment may be damaged by water hammer. Motive air pressure should be adjusted to set the secondary pressure higher than the pressure set in step 6. (Using motive air, secondary pressure cannot be set to a pressure lower than that set in step 6).
8. Slowly, fully open the shut-off valve at the outlet of the PN-DR.
9. When shutting down the system, always close the outlet shut-off valve first and then the inlet valve.

## Maintenance



Take measures to prevent people from coming into direct contact with product outlets. Failure to do so may result in burns or other injury from the discharge of fluids.



Be sure to use only the recommended components when repairing the product, and NEVER attempt to modify the product in any way. Failure to observe these precautions may result in damage to the product or burns or other injury due to malfunction or the discharge of fluids.

### Operational Check

To ensure long service life of the PN-DR, the following inspection and maintenance should be performed regularly.

Part	Inspection and Maintenance Frequency
Screen	Disassemble and clean annually. If there is substantial blockage, install a strainer (approximately 60 mesh) ahead of PN-DR.
Main Valve, Valve Seat	If there is chattering or dirt, premature wear may result.
Valve Stem, Spacer (Slide Bearing)	If hunting or chattering takes place, premature wear may result.
Bellows	If hunting or chattering takes place, cracks or fatigue may develop in a short period of time.
Seal Ring	Replace annually. Premature wear may occur.
Packing	Replace annually. Premature wear may occur.

## Disassembly



When disassembling or removing the product, wait until the internal pressure equals atmospheric pressure and the surface of the product has cooled to room temperature. Disassembling or removing the product when it is hot or under pressure may lead to discharge of fluids, causing burns, other injuries or damage.

It is a recommended practice to dismantle and inspect the PN-DR once a year for preventive maintenance purposes. It is especially important to perform an inspection immediately after the initial run of a new line or before or after equipment such as a heater is out of service for a long period of time. (Installation, inspection, maintenance, repairs, disassembly, adjustment and valve opening/closing should be carried out only by trained maintenance personnel.)

Remove all steam/pressurized air from the piping (both upstream and downstream). Remove all motive air pressure.

Wait for the body to cool before attempting to remove the PN-DR from the line. Then remove the PN-DR from the piping, and secure it in a vise to perform the inspection.

### Dismantling the Adjusting Section

Loosen the adjustment handle completely and remove the cover bolts. After removing the cover, you will see the steel ball, the spring retainer and the coil spring.  
⇒ Check for seizure or any damaged screw threads.

Remove the retaining ring. The seal ring and the packing can be removed by loosening the adjustment handle and the holder nut.

⇒ Check and make sure that the seal ring is not deteriorated and the packing has no abnormality.

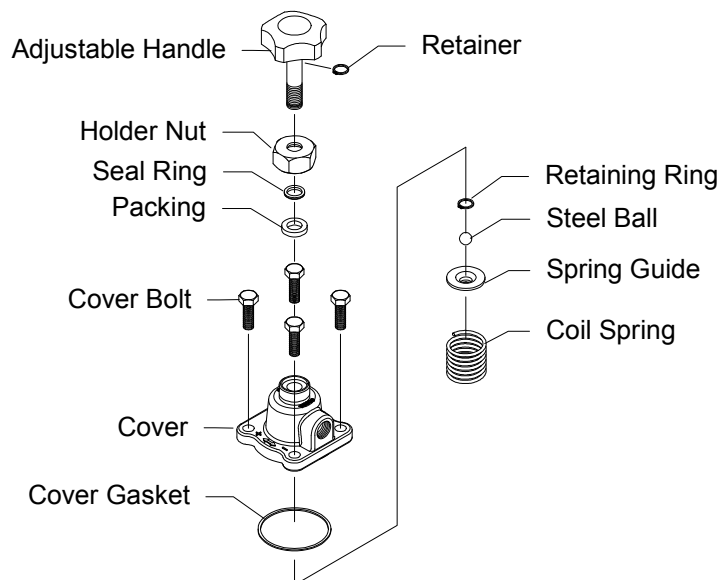

### Dismantling the Bellows Section

Remove the bellows from the body, then the valve stem. Pinch the straight sections of the snap ring that is holding the spacer together using a tool such as a needle-nose pliers and remove the snap ring. Remove the spacer.

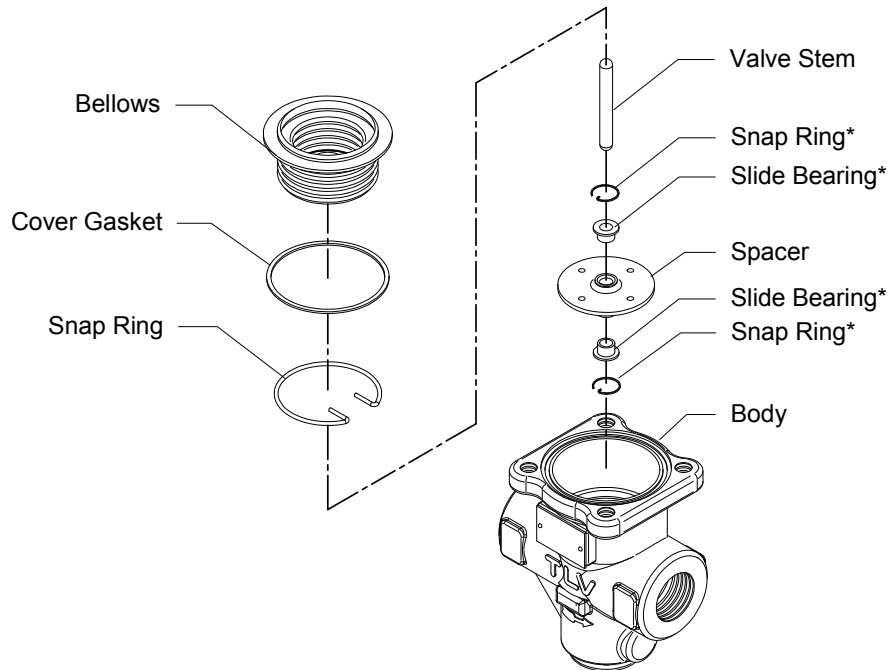

\*Cannot be removed individually as it is incorporated with the spacer and must be replaced as a set with the spacer.

### Dismantling the Valve Section

Loosen the valve seat with a wrench and remove it from the body. The coil spring is exerting an upward pressure on the bottom of the valve seat, so be careful that the valve seat is not thrown out. After removing the valve seat, remove the main valve, the coil spring and the screen.

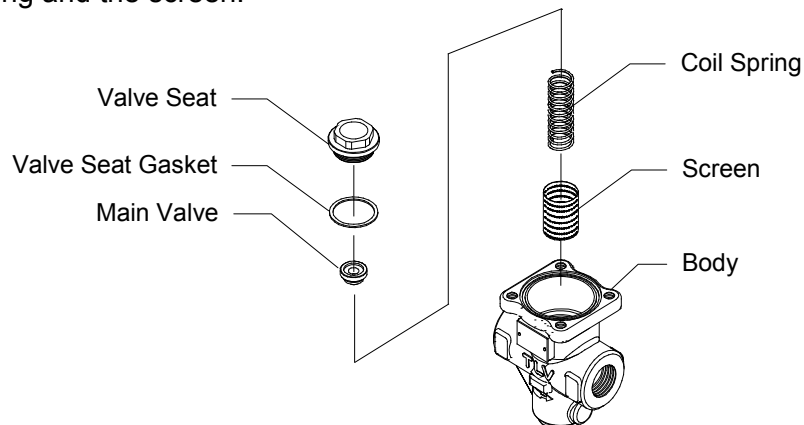

### Cleaning

After inspection and removal of any abnormality, clean and reassemble the parts. The following parts will require cleaning before reassembly:

Threads of the adjustment handle, threads of the cover, bellows, holder nut, valve stem, main valve, valve seat, spacer (including slide bearing), screen

It is permissible to clean using water. However, cleaning with a mild detergent is recommended for more effective cleaning.

**Exploded View**

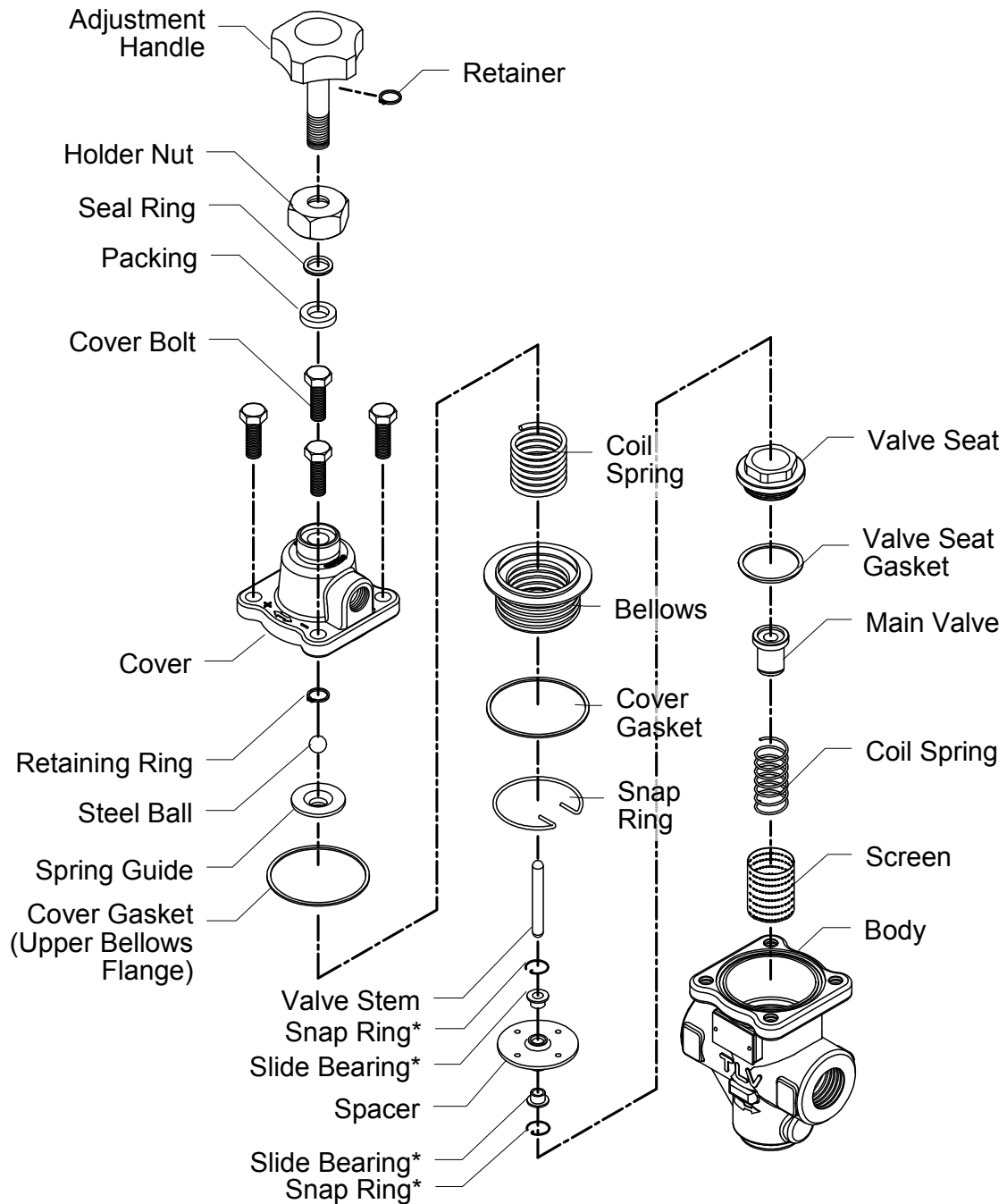

\*Cannot be removed individually as it is incorporated with the spacer and must be replaced as a set with the spacer.



## Reassembly

Reassemble the unit using the same procedure as used for disassembling it; but in reverse order. In addition, observe the following precautions:

1. The PTFE gasket may be re-used if free from fault, crushing or deformation.
2. Apply anti-seize to the steel ball and threaded portions of screws, bolts and the adjustment handle. Apply a small amount of anti-seize agent to the threads of the valve seat carefully to ensure it does not come into contact with other parts.
3. Fasten the bolts one at a time in a diagonal pattern alternately to provide uniform seating.
4. After assembly, make sure that the valve stem operates smoothly without binding.

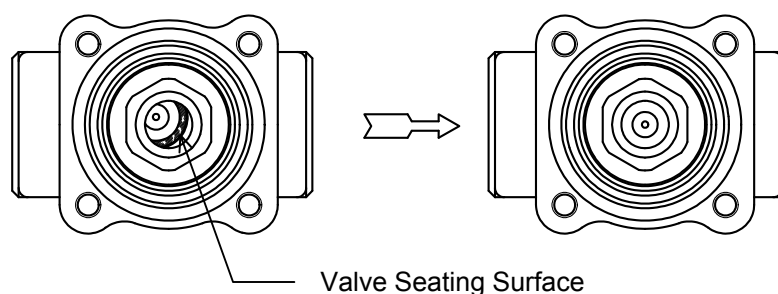

As shown in the figures above, when the valve is tightened it may become off-centered on the valve seat. If this occurs, move the valve back to center.

5. Standard torque for fastening the respective screws and the width across flats of the tools to be used are as follows:

Part	Torque		Distance Across Flats	
	N·m	(lbf·ft)	mm	(in)
Cover Bolt	25	19	13	( $1/2$ )
Valve Seat	70	(51)	27	( $1\frac{1}{16}$ )
Holder Nut	10	(7)	30	( $1\frac{3}{16}$ )

(1 N·m  $\approx$  10 kg·cm)

NOTE: - If drawings or other special documentation were supplied for the product, any torque given there takes precedence over values shown here.

## Troubleshooting



When disassembling or removing the product, wait until the internal pressure equals atmospheric pressure and the surface of the product has cooled to room temperature. Disassembling or removing the product when it is hot or under pressure may lead to discharge of fluids, causing burns, other injuries or damage.

This product is shipped after stringent checks and inspection, and should perform its intended function for a long period of time without failure. However, should there be any problem encountered in the operation of the PN-DR, consult the troubleshooting guide below. Problems are classified as follows:

1. The secondary pressure does not increase
2. The secondary pressure cannot be adjusted or increases abnormally
3. Hunting (fluctuation of the secondary pressure) occurs
4. Chattering (a heavy mechanical noise) occurs
5. Abnormal noises

Major causes for the above problems are usage under non-specified conditions (out of specification), insufficient pressure or flow rate, and clogs by dirt and scale.

To ensure performance for a long period of time, it is recommended that the "Acceptable Operating Range", "Correct Usage of the PN-DR Direct-acting Pressure Reducing Valve" and "Adjustment" sections be reviewed.

Problem	Symptom	Cause	Remedy
The secondary pressure does not rise	Pressure does not increase	No steam/air is being supplied	Check the primary/secondary piping and valves of the unit
		The valve at the primary side is closed	
		No motive air is being supplied	Check motive air supply
		The entrance to the screen or strainer is clogged	Clean or blow down
		Flow rate exceeds specifications	Check the flow rate; check the model selection, replace with a more suitable unit if necessary
		It exceeds the adjustable pressure range	Check the model selection, replace with a more suitable unit if necessary
The secondary pressure cannot be adjusted or increases abnormally	Adjustment is difficult and set pressure varies	The flow rate is too low	Check the flow rate; check the model selection, replace with a unit that has smaller nominal diameter or more a suitable unit if necessary
		Pressure fluctuation at the primary side is large	Check the primary pressure; check the model selection, replace with a more suitable unit if necessary
		Buildup on the valve stem prevents smooth movement through the spacer	Clean and inspect the valve stem and spacer
		Flow rate fluctuation is too large	Check the flow rate, re-set the pressure; check the model selection, replace with a more suitable unit if necessary
		The motive air pressure fluctuates	Check motive air pressure

Troubleshooting continued on next page

Problem	Symptom	Cause	Remedy	
The secondary pressure cannot be adjusted or increases abnormally	Adjustment is difficult and set pressure varies	The adjustment handle has seized	Replace with a new adjustment handle	
		The holes in the spacer are clogged	Clean	
		The slide bearing is distorted or damaged	Replace with a new spacer (when replacing the slide bearing or snap ring, these parts need to be replaced as a set with the spacer)	
		The bellows is distorted or damaged	Replace with a new bellows	
		The selected model is inappropriate for the service conditions (specifications)	Check the model selection, replace with a more suitable unit if necessary	
	Upon closing the valves at the secondary side, the secondary pressure abruptly rises as high as the primary pressure	The bypass valve is leaking	Check, clean, and replace with a new valve if necessary	
		There is a build-up of dirt on or damage to the main valve or the valve seat	Clean and align	
Hunting or chattering occurs	Occurs at low steam/air demand	The flow rate is too low	Check the flow rate; check the model selection, replace with a unit that has smaller nominal diameter or a more suitable unit if necessary	
		Hunting never stops	There is too high a reduction ratio	Use two-stage reduction
			The selected model is inappropriate for the service conditions (specifications)	Check the model selection, replace with a more suitable unit if necessary
	Chattering never stops	Condensate is entrained	Install a steam trap; check the piping	
		The selected model is inappropriate for the service conditions (specifications)	Check the model selection, replace with a more suitable unit if necessary	
	Abnormal noises	Makes a high-pitched noise	The required pressure reduction exceeds specifications	Use two-stage reduction
Flow rate exceeds specifications			Check the flow rate; check the model selection, replace with a unit that has larger nominal diameter or a more suitable unit if necessary	
The valve installed close to the reducing valve opens/closes too quickly			Install the valve at as great a distance away as possible	

NOTE: When replacing parts with new, use the parts list for reference and replace with parts from the Maintenance Kit, Repair Kit, etc. (Please note that replacement parts are only available in pre-packaged kits.)

## Product Warranty

1. Warranty Period  
One year following product delivery.
2. Warranty Coverage  
TLV CO., LTD. warrants this product to the original purchaser to be free from defective materials and workmanship. Under this warranty, the product will be repaired or replaced at our option, without charge for parts or labor.
3. This product warranty will not apply to cosmetic defects, nor to any product whose exterior has been damaged or defaced; nor does it apply in the following cases:
  - 1) Malfunctions due to improper installation, use, handling, etc., by other than TLV CO., LTD. authorized service representatives.
  - 2) Malfunctions due to dirt, scale, rust, etc.
  - 3) Malfunctions due to improper disassembly and reassembly, or inadequate inspection and maintenance by other than TLV CO., LTD. authorized service representatives.
  - 4) Malfunctions due to disasters or forces of nature.
  - 5) Accidents or malfunctions due to any other cause beyond the control of TLV CO., LTD.
4. Under no circumstances will TLV CO., LTD. be liable for consequential economic loss damage or consequential damage to property.

\* \* \* \* \*

For Service or Technical Assistance:

Contact your **TLV** representative or your regional **TLV** office.

### Manufacturer

**TLV** CO., LTD.  
881 Nagasuna, Noguchi  
Kakogawa, Hyogo 675-8511 JAPAN  
Tel: 81-(0)79 - 427 - 1800