



Manufacturer
TLV. CO., LTD.
Kakogawa, Japan
is approved by LRQA LTD. to ISO 9001/14001



Instruction Manual

Pressure Reducing Valve for Air **A-COSR-10**

Contents

Introduction	1
Safety Considerations	2
Specifications	4
Acceptable Operating Range	4
Correct Usage of the A-COSR Pressure Reducing Valve ..	5
Configuration	7
Installation	8
Adjustment	11
Maintenance	12
Disassembly	13
Reassembly	17
Troubleshooting	18
Product Warranty	20

Introduction

Thank you for purchasing the **TLV** A-COSR pressure reducing valve for air.

This product has been thoroughly inspected before being shipped from the factory. When the product is delivered, before doing anything else, check the specifications and external appearance to make sure nothing is out of the ordinary. Also be sure to read this manual carefully before use and follow the instructions to be sure of using the product properly.

The **TLV** pressure reducing valve for air, model A-COSR provides a more stable secondary pressure than conventional reducing valves. The A-COSR is designed for long service life, with all major components made of stainless steel for superior durability.





If detailed instructions for special order specifications or options not contained in this manual are required, please contact **TLV** for full details.

This instruction manual is intended for use with the model(s) listed on the front cover. It is needed not only for installation, but also for subsequent maintenance, disassembly/reassembly and troubleshooting. Please keep it in a safe place for future reference.

Safety Considerations

- Read this section carefully before use and be sure to follow the instructions.
- Installation, inspection, maintenance, repairs, disassembly, adjustment and valve opening/closing should be carried out only by trained maintenance personnel.
- The precautions listed in this manual are designed to ensure safety and prevent equipment damage and personal injury. For situations that may occur as a result of erroneous handling, three different types of cautionary items are used to indicate the degree of urgency and the scale of potential damage and danger: DANGER, WARNING and CAUTION.
- The three types of cautionary items above are very important for safety: be sure to observe all of them as they relate to installation, use, maintenance, and repair. Furthermore, TLV accepts no responsibility for any accidents or damage occurring as a result of failure to observe these precautions.

Symbols

	Indicates a DANGER, WARNING or CAUTION item.
	Indicates an urgent situation which poses a threat of death or serious injury
	Indicates that there is a potential threat of death or serious injury
	Indicates that there is a possibility of injury or equipment / product damage

	Install properly and DO NOT use this product outside the recommended operating pressure, temperature and other specification ranges. Improper use may result in such hazards as damage to the product or malfunctions that may lead to serious accidents. Local regulations may restrict the use of this product to below the conditions quoted.
	Use hoisting equipment for heavy objects (weighing approximately 20 kg or more). Failure to do so may result in back strain or other injury if the object should fall.
	Take measures to prevent people from coming into direct contact with product outlets. Failure to do so may result in burns or other injury from the discharge of fluids.
	When disassembling or removing the product, wait until the internal pressure equals atmospheric pressure and the surface of the product has cooled to room temperature. Disassembling or removing the product when it is hot or under pressure may lead to discharge of fluids, causing burns, other injuries or damage.

Safety considerations are continued on the next page.

 CAUTION	Be sure to use only the recommended components when repairing the product, and NEVER attempt to modify the product in any way.
	Failure to observe these precautions may result in damage to the product and burns or other injury due to malfunction or the discharge of fluids.
	Do not use excessive force when connecting threaded pipes to the product.
	Over-tightening may cause breakage leading to fluid discharge, which may cause burns or other injury.
	Use only under conditions in which no freeze-up will occur.
	Freezing may damage the product, leading to fluid discharge, which may cause burns or other injury.
	Use only under conditions in which no water hammer will occur.
	The impact of water hammer may damage the product, leading to fluid discharge, which may cause burns or other injury.

Specifications



Install properly and **DO NOT** use this product outside the recommended operating pressure, temperature and other specification ranges. Improper use may result in such hazards as damage to the product or malfunctions which may lead to serious accidents. Local regulations may restrict the use of this product to below the conditions quoted.



DO NOT use the trap in excess of the maximum operating pressure differential; such use could make discharge impossible (blocked).



Use only under conditions in which no freeze-up will occur. Freezing may damage the product, leading to fluid discharge, which may cause burns or other injury.

Refer to the product nameplate for detailed specifications.

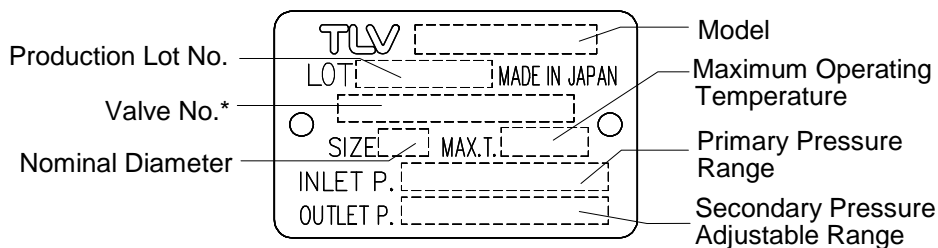

* Valve No. is displayed for products with options. This item is omitted from the nameplate when there are no options.

Acceptable Operating Range

Use	Model	Primary Pressure Range (MPaG)	Secondary Pressure Adjustable Range (MPaG)	Minimum Differential Pressure (MPa)	Maximum Operating Temperature (°C)	Minimum Adjustable Flow Rate
For Air	A-COSR-10	0.1 - 0.9	0.05 - 0.7	0.05	100	10% of rated flow rate

Correct Usage of the A-COSR Pressure Reducing Valve



Install properly and DO NOT use this product outside the recommended operating pressure, temperature and other specification ranges. Improper use may result in such hazards as damage to the product or malfunctions which may lead to serious accidents. Local regulations may restrict the use of this product to below the conditions quoted.

1. The A-COSR should be operated only within its specifications.
2. Installing an ON / OFF Valve (Solenoid Valve or Motorized Valve)

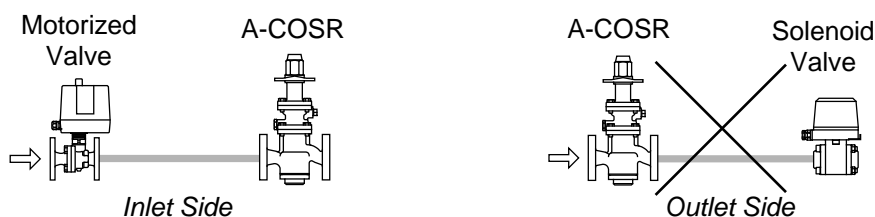

If an on-off valve, such as a motorized valve is required, install it at the inlet side of the A-COSR. If a solenoid valve is installed at the outlet of the reducing valve, its opening and closing will cause heavy chattering and may lead to damage of the piston and main valve. (When the on-off valve opens, the secondary pressure of the reducing valve changes from zero to the set pressure. Passing through an area of the reducing ratio of less than 10:1, where adjustment is impossible, chattering occurs momentarily.)

3. Installing a Safety Valve

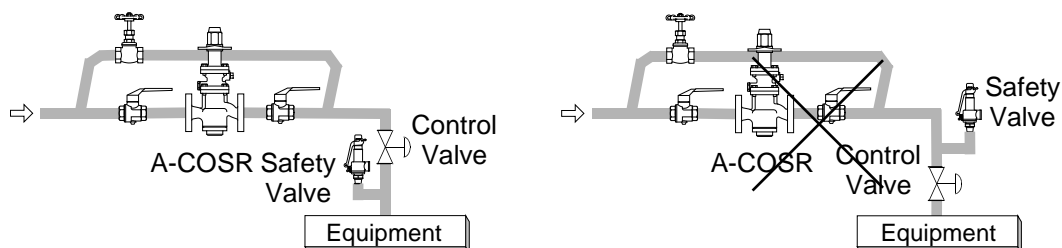

When installing a safety valve to protect the air equipment, be sure to install it on the air equipment or directly before the inlet of the air equipment. If the safety valve is installed on the outlet side of the A-COSR between the A-COSR and a control valve, an eventual pressure rise could activate the safety valve.

4. Precautions for the Installation of Additional Fittings Before or After the Reducing Valve

In order to ensure stable air flow, the piping upstream and downstream of the reducing valve must be straight runs. If a pressure reducing valve is installed either directly before or after an elbow or control valve, unevenness in air flow may result in chattering and unstable pressure.

To ensure stable air flow, it is recommended that the pressure reducing valve be installed on straight runs of piping, as illustrated below.

① Inlet (primary side) of the pressure reducing valve

Maintain a straight piping run of **10 d or more** when a manual valve, a strainer or an elbow, etc. is installed.

(Example: if nominal size is 25 mm, have 250 mm or more)

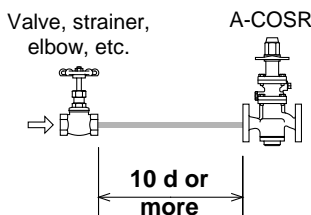

NOTE: d = pipe diameter

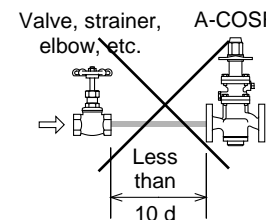

Maintain a straight piping run of **30 d or more** when an automated valve (on-off valve) is installed.

(Example: if nominal size is 25 mm, have 750 mm or more)

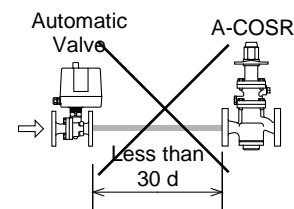
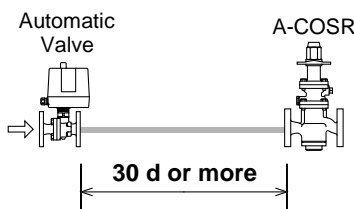

② Outlet (secondary side) of the pressure reducing valve

Maintain a straight piping run of **15 d or more** when a manual valve, a strainer or an elbow, etc. is installed.

(Example: if nominal size is 25 mm, have 375 mm or more)

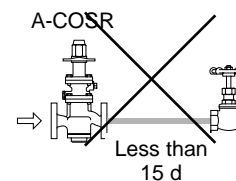
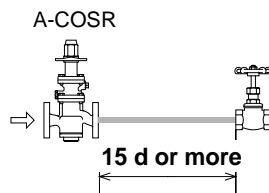

Maintain a straight piping run of **30 d or more** when a safety valve is installed.

(Example: if nominal size is 25 mm, have 750 mm or more)

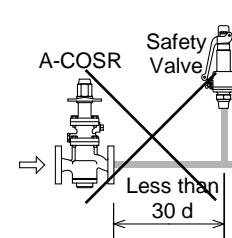
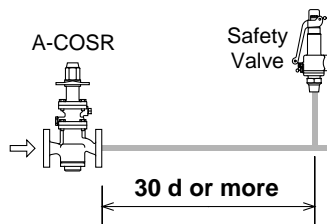

Maintain a straight piping run of **30 d or more** when another pressure reducing valve is installed. (Two-stage pressure reduction)

(Example: if nominal size is 25 mm, have 750 mm or more)

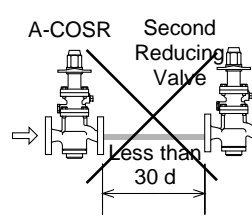
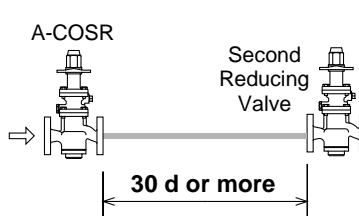

Maintain a straight piping run of **30 d or more** when a control valve or an automated valve (on-off valve) is installed.

(Example: if nominal size is 25 mm, have 750 mm or more)

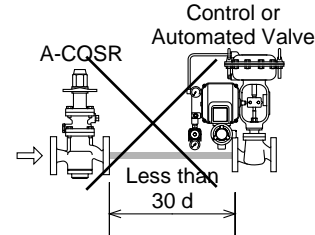
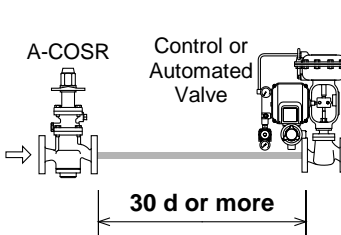

Configuration

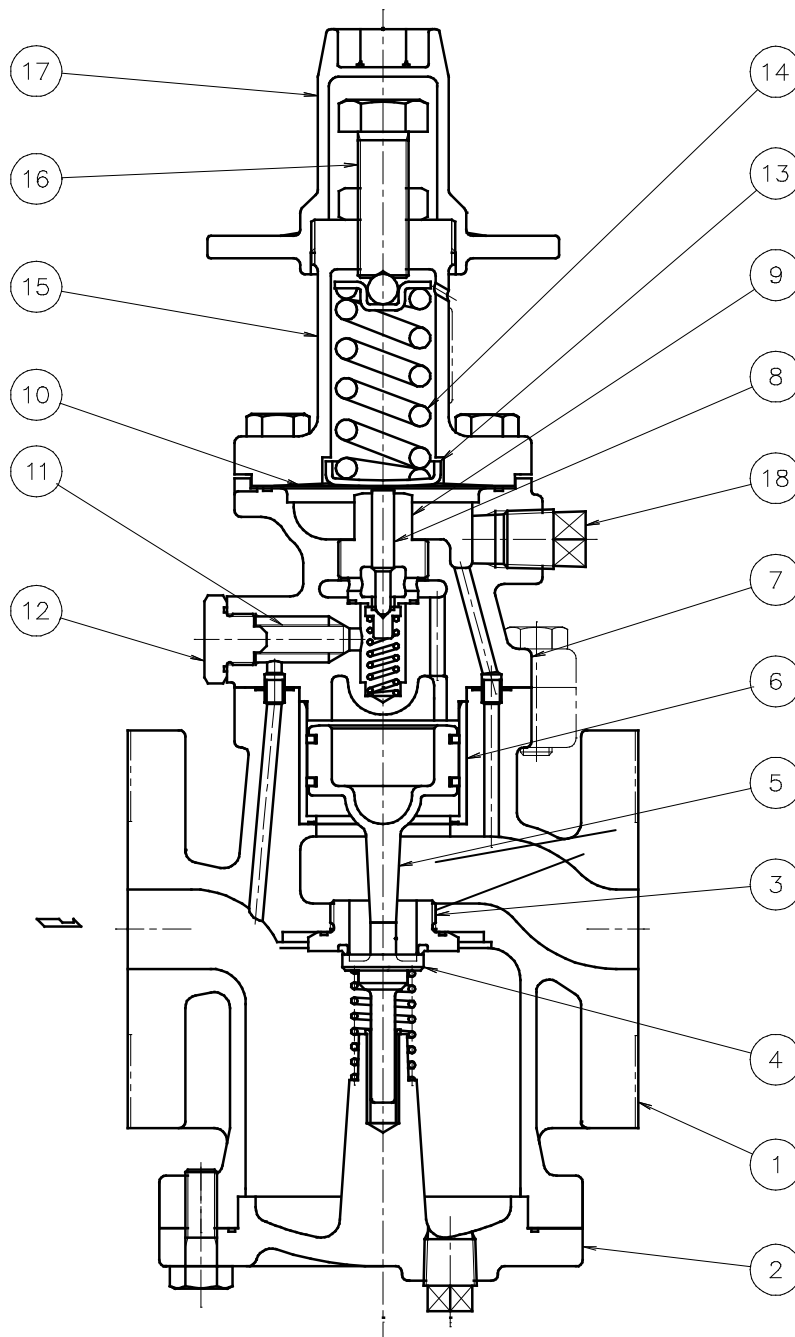

No.	Name	No.	Name
1	Main Body	10	Diaphragm
2	Cover	11	Pilot Screen
3	Main Valve Seat	12	Pilot Screen Holder
4	Main Valve	13	Diaphragm Support
5	Piston	14	Coil Spring
6	Cylinder	15	Spring Housing
7	Pilot Valve Body	16	Adjustment Screw
8	Pilot Valve	17	Spanner Cap
9	Pilot Valve Seat	18	Plug – Sensing Line Port

Installation



Install properly and **DO NOT** use this product outside the recommended operating pressure, temperature and other specification ranges. Improper use may result in such hazards as damage to the product or malfunctions which may lead to serious accidents. Local regulations may restrict the use of this product to below the conditions quoted.



Use hoisting equipment for heavy objects (weighing approximately 20 kg or more). Failure to do so may result in back strain or other injury if the object should fall.



Take measures to prevent people from coming into direct contact with product outlets. Failure to do so may result in burns or other injury from the discharge of fluids.

Installation, inspection, maintenance, repairs, disassembly, adjustment and valve opening/closing should be carried out only by trained maintenance personnel.

1. Blowdown

Before installing the A-COSR, be sure to blow down all piping thoroughly. If this is not possible, perform a blowdown using the bypass valve.

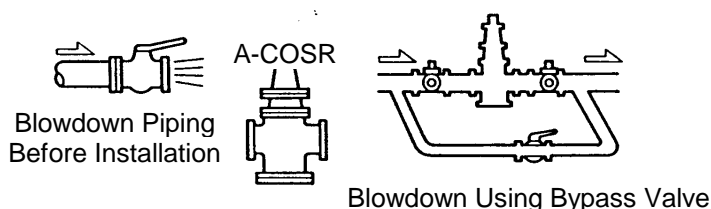

Blowdown is especially important for newly installed piping or after the system has been shut down for a long period of time.

2. Removing Seal and Cap

Before installation, be sure to remove all protective seals and caps. (Found in 2 locations, on the product inlet and outlet.)

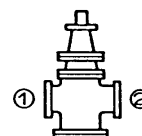

3. Installation Angle

Install the A-COSR vertically, so that the arrow mark on the body points horizontally in the direction of air flow.

Allowable inclination is 10 degrees in the fore-aft direction and 15 degrees in the plane perpendicular to the air flow line.

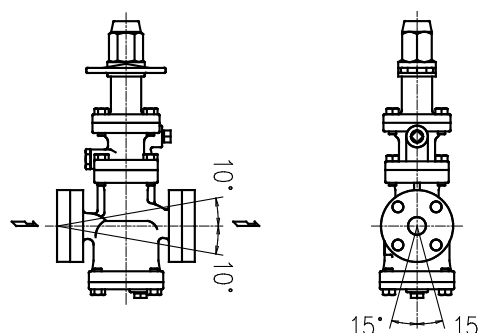

4. Spacer Installation

If spacing adjustment is necessary to accommodate installation, install a spacer on the outlet flange. The spacer should consist of a spacer, gaskets, bolts and nuts.

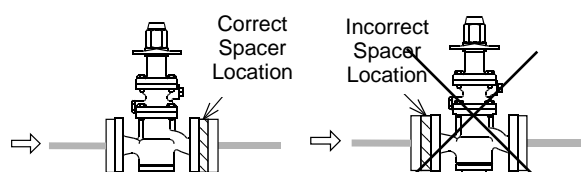

Fit gaskets to both sides of the spacer between the A-COSR outlet and the pipe flange. Fasten with bolts and nuts.

5. Piping Support

Install the A-COSR, paying attention to avoid excessive load, bending and vibration.

Support the inlet and outlet pipes securely.

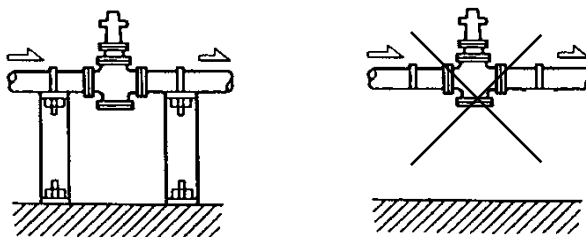

6. Maintenance Space

Leave sufficient space for maintenance, inspection and repair.

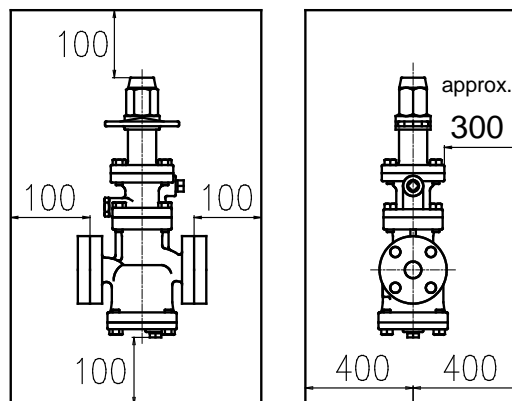

(Unit: mm)

7. Piping Size

If it is expected that the secondary air flow velocity will be more than 30 m/s, install a diffuser in order to keep the flow velocity below 30 m/s. If the distance between the reducing valve and the air equipment is great, a possible drop in pressure should be taken into consideration when selecting the piping size. Strainer should be angled in the 3 o'clock or 9 o'clock positions for horizontal installations to prevent condensate accumulation.

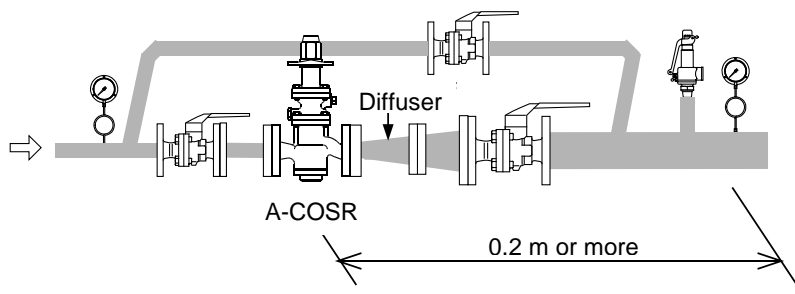

Straight-run Piping Lengths: Upstream = 10 d or more; Downstream = 15 d or more (d = pipe diameter)

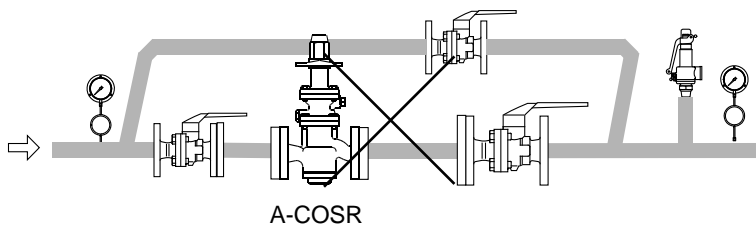

8. Accessories

A strainer should always be installed ahead of the A-COSR. The strainer should be 60 mesh or finer, but not so fine as to constrict flow area resulting in a pressure drop. The strainer should be installed horizontally with the basket at the 3 or 9 o'clock position in order to prevent condensate accumulation.

Always install a shut-off valve, pressure gauge and bypass line at both inlet and outlet.

Ball valves, which will not retain condensate, are recommended for inlet and outlet shut-off valves. The bypass pipe should be at least one half of the size of the inlet (primary side) pipe.

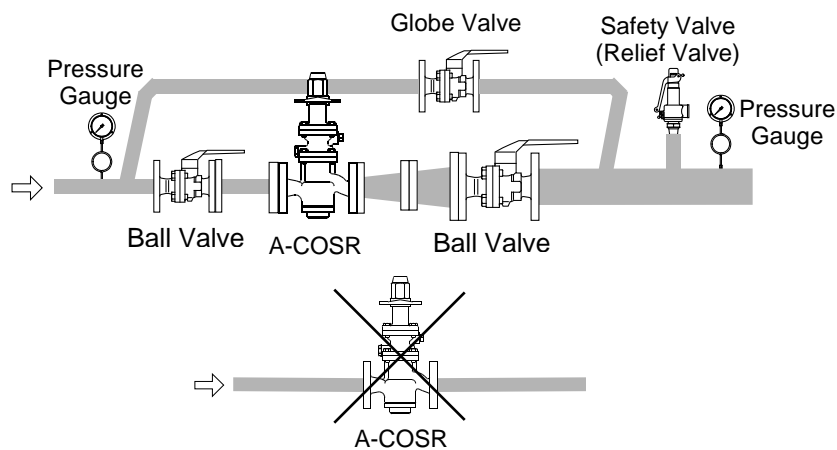

Adjustment

The A-COSR reducing valve should be properly adjusted for protection of the air equipment.

1. It is necessary to blow down all pipe lines thoroughly. The blowdown is especially important if the line is new or has been shut down for a long period of time. Take particular care to ensure that matter such as condensate and dirt does not remain inside the air equipment.
(Stay clear of any pressurized blow-out from the safety valve.)
2. Make sure that the shut-off valve and the bypass valve located upstream and downstream of the A-COSR are completely closed.
3. Remove the spanner cap, loosen the locknut and turn the adjustment screw counter-clockwise to reduce tension on the coil spring.

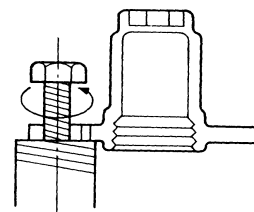

Loosen the locknut

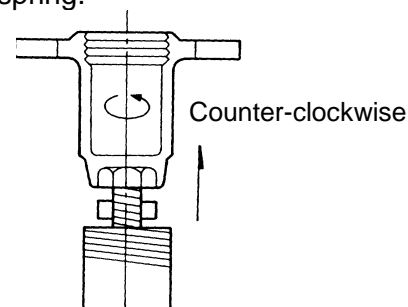

Loosen the adjustment screw

4. Slowly, fully open the shut-off valve at the inlet of the A-COSR. Allow sufficient time for condensate remaining at the inlet of the A-COSR to be discharged.
5. Slightly open the shut-off valve at the outlet of the A-COSR.
6. Turn the adjustment screw until the desired outlet pressure is obtained. Wait several minutes.

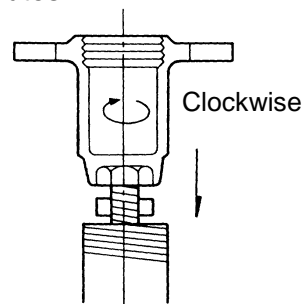

Tighten the Adjustment Screw
Increase Pressure

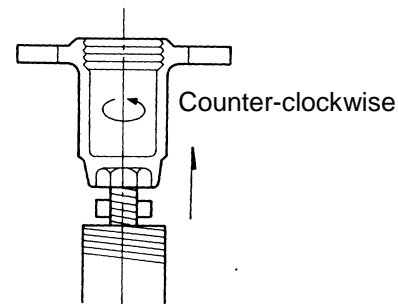

Loosen the Adjustment Screw
Decrease Pressure

7. Slowly, fully open the shut-off valve at the outlet of the A-COSR.
8. After setup, retighten the locknut and replace the cap.
9. When shutting down the system, always close the outlet shut-off valve first and then the inlet valve.

Maintenance



Take measures to prevent people from coming into direct contact with product outlets. Failure to do so may result in burns or other injury from the discharge of fluids.



Be sure to use only the recommended components when repairing the product, and NEVER attempt to modify the product in any way. Failure to observe these precautions may result in damage to the product or burns or other injury due to malfunction or the discharge of fluids.

Operational Check

To ensure long service life of the A-COSR, the following inspection and maintenance should be performed regularly.

Part	Inspection and Maintenance Frequency
Pilot Screen	Disassemble and clean annually. If there is substantial blockage, install a strainer (approximately 60 mesh) ahead of the A-COSR.
Main Valve, Main Valve Seat, Pilot Valve and Pilot Valve Seat	Replace after approximately 15,000 hours. If there is chattering or dirt, premature wear may result.
Piston Ring	Replace after approximately 8,000 hours. If there is chattering or if scale build-up is severe, premature wear may result.
Piston	Replace after approximately 30,000 hours. If hunting or chattering takes place, premature wear may result.
Diaphragm	Replace after approximately 30,000 hours. If hunting or chattering takes place, cracks or fatigue may develop in a short period of time.

Disassembly



Use hoisting equipment for heavy objects (weighing approximately 20 kg or more). Failure to do so may result in back strain or other injury if the object should fall.



When disassembling or removing the product, wait until the internal pressure equals atmospheric pressure and the surface of the product has cooled to room temperature. Disassembling or removing the product when it is hot or under pressure may lead to discharge of fluids, causing burns, other injuries or damage.

It is a recommended practice to dismantle and inspect the A-COSR once a year for preventive maintenance purposes. It is especially important to perform an inspection immediately after the initial run of a new line or before or after equipment that heater is out of service for a long period of time. (Installation, inspection, maintenance, repairs, disassembly, adjustment and valve opening/closing should be carried out only by trained maintenance personnel.)

Remove all pressure from the piping (both upstream and downstream). Then remove inlet and outlet flange retaining bolts and nuts to permit removal of the A-COSR. Secure the A-COSR in a vise to perform the inspection.

Disassembling the Adjustment Section

Loosen the adjustment screw completely and remove the bolts. Having removed the spring housing, you will see the diaphragm support, coil spring and spring guide. Check for seizure or any damaged screw threads.

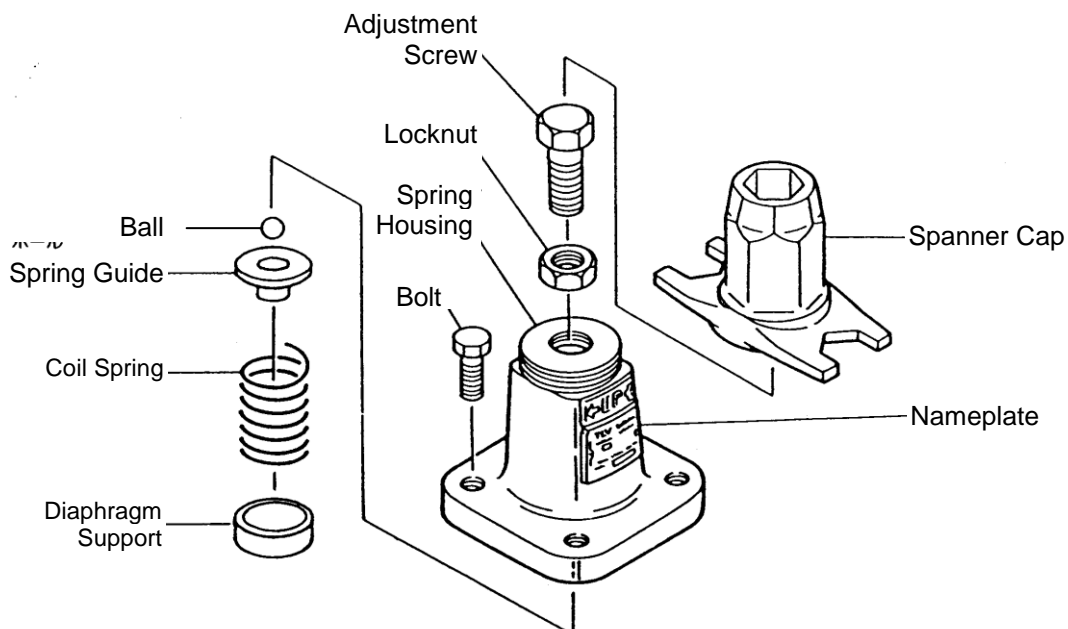

Disassembling the Pilot Section

The diaphragm is removed by utilizing the notch in the pilot body. Loosen the pilot valve seat with a box wrench and remove it. Lift the pilot valve spring up and out with a pair of tweezers. Then loosen and remove the pilot screen holder to remove the pilot screen.

Check for any fault on the pilot valve seat, flaws on the gaskets and clogging of the pilot screen.

Check for deformation, corrosion or faults on the diaphragm. The diaphragm should be convex (open downward), with the printed "UP" mark on the top.

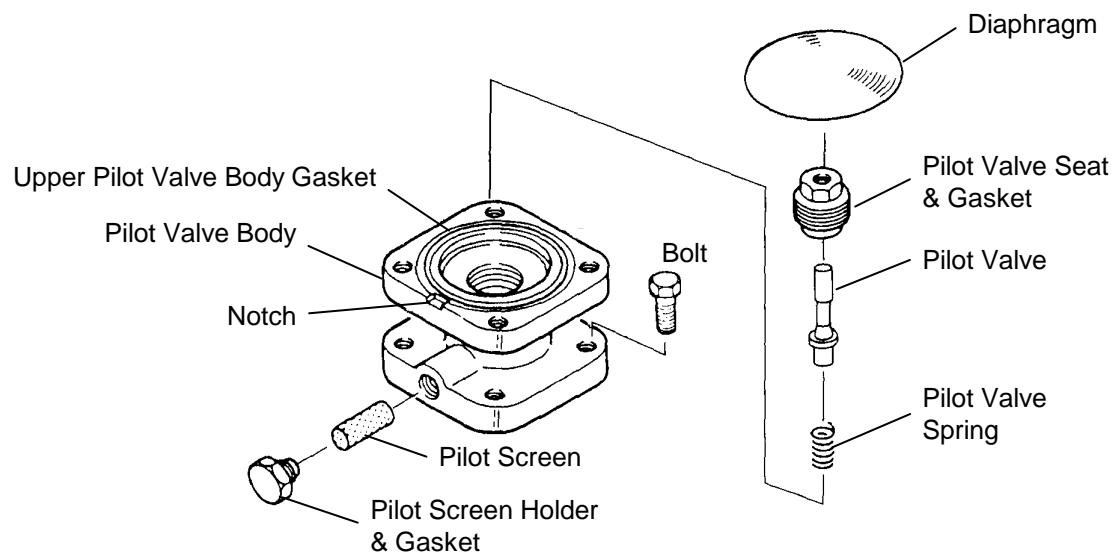

Disassembling the Piston

Remove the pilot valve body after loosening and removing the bolts. During this process, pay attention not to lose the connecting tubes (2).

Remove the piston and the cylinder from the main body. Then remove the piston rings and the tension rings from the piston. Do not apply too much force when removing the piston rings and tension rings.

Inspect the interior of the cylinder, the exterior of the piston rings, the small hole on the piston and the gaskets for any fault or abnormality.

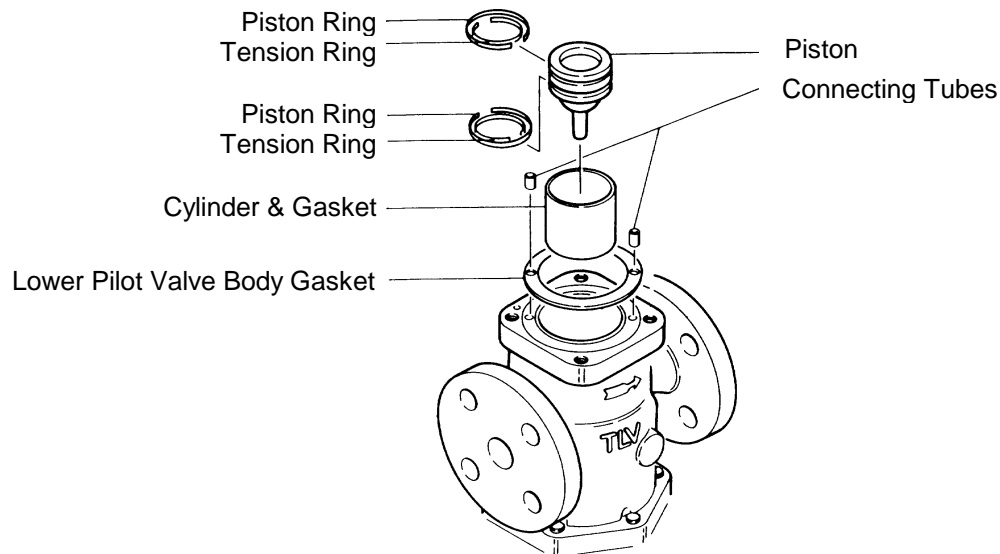

Disassembling the Main Valve

Turn the A-COSR upside down for easy dismantling of the main valve.

Remove the cover plug or loosen the bolts and remove the cover. Remove the main valve and the main valve spring. Loosen the main valve seat by using a box wrench and remove from the main body.

Check for damage on the seating and sliding surfaces of the main valve and main valve holder, the seating surface of the main valve seat, and for damage on the gaskets.

At start-up following shut-down for a long period, always blow down the piston section of the body through the plug (option).

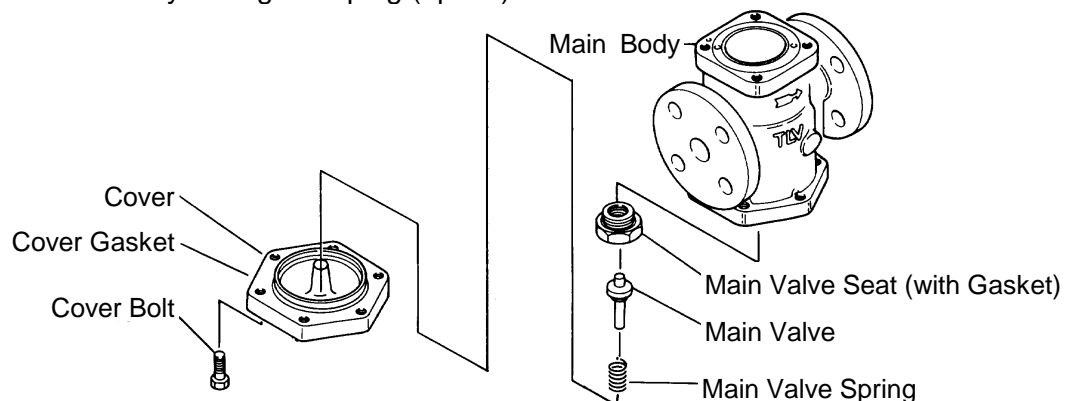

Cleaning

After inspection and removal of any abnormality, clean and reassemble the parts. The following parts will require cleaning before reassembly:

Cover Plug / Cover	Main Valve	Cylinder
Pilot Screen	Main Valve Holder	Pilot Valve
Main Valve Seat	Piston	Pilot Valve Seat
	Piston Ring	Adjustment Screw

It is permissible to clean using water, however cleaning with a mild detergent is recommended for more effective cleaning.
(Coat threaded position with anti-seize after cleaning.)

Exploded View

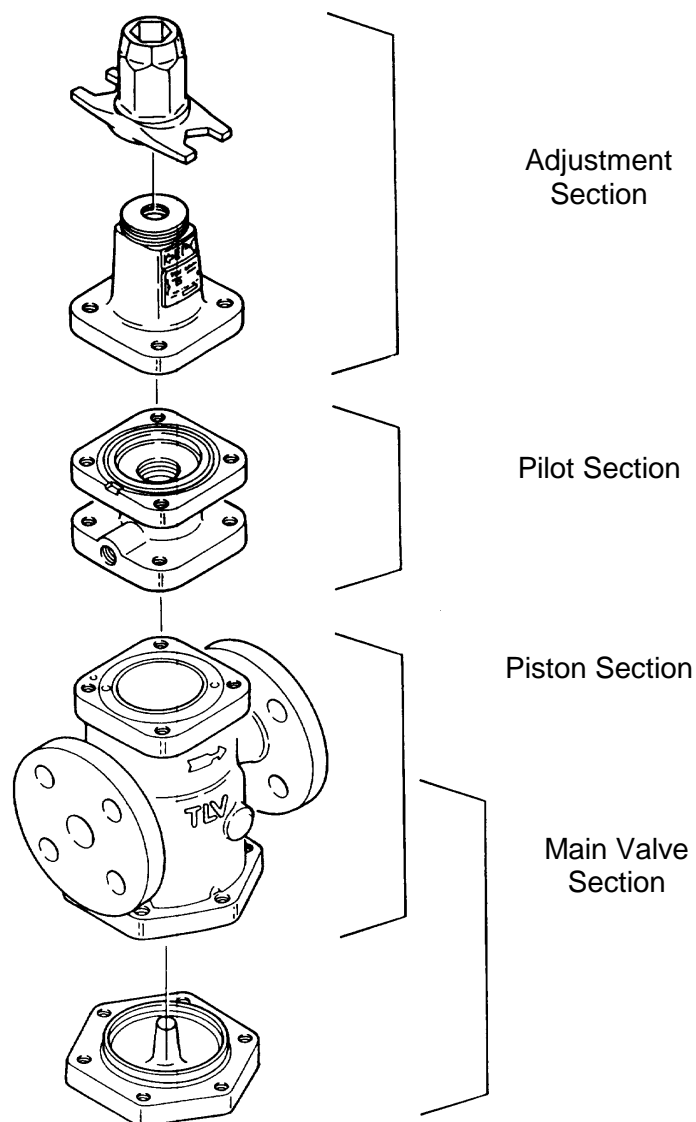

Reassembly

Assemble the unit using the same procedure as used for disassembling it; but in reverse order. Observe the following precautions:

1. The PTFE gaskets may be re-used if free from fault, crushing or deformation.
2. Apply anti-seize to the threaded portion of screws and bolts, the spring retainer, ball and adjustment screw. Apply a small amount of anti-seize to the threads of the main valve seat, pilot valve seat and pilot screen holder. Apply anti-seize carefully to ensure it does not come into contact with other parts.
3. Fasten the bolts one at a time in an alternating diagonal pattern to provide uniform seating.
4. After assembly, make sure that the piston and the pilot guide operate smoothly without binding.

Assembling the Piston Ring

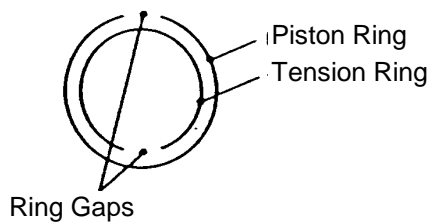

- 1) Fit the piston ring to the outside of the tension ring.
- 2) The ring gaps should be opposite each other.

5. Standard fastening torque and the distance across flats for the tools to be used are as follows:

Part	A-COSR Connection Size (mm)	Distance Across Flats (mm)	Tightening Torque (N·m)
Bolts for Spring Housing / Pilot Body	All	17	40
Pilot Valve Seat	All	19	70
Pilot Screen Holder	All	24	40
Bolt for Pilot Body	Size 15 – 40	17	60
	50	19	70
Main Valve Seat	15, 20	36	100
	25	41	125
	32, 40	60	250
	50	70	300
Cover Bolt	15 - 40	17	60
	50	19	70

Caution: If a torque greater than that recommended is applied, the A-COSR or components may be damaged.

1 N·m ≈ 10 kg·cm

Troubleshooting



When disassembling or removing the product, wait until the internal pressure equals atmospheric pressure and the surface of the product has cooled to room temperature. Disassembling or removing the product when it is hot or under pressure may lead to discharge of fluids, causing burns, other injuries or damage.

This product is shipped after stringent checks and inspection and should perform its intended function for a long period of time without failure. However, should there be any problem encountered in the operation of the A-COSR, consult the troubleshooting guide below.

Problems are classified as follows:

1. The secondary pressure does not increase.
2. The secondary pressure cannot be adjusted or increases abnormally.
3. Hunting (fluctuation of the secondary pressure) occurs.
4. Chattering (a heavy mechanical noise) occurs.
5. Abnormal noises.

Major causes for the above problems are usage under non-specified conditions (out of specification), insufficient pressure or flow rate, and clogs by dirt and scale. To ensure performance for a long period of time, it is recommended that the "Acceptable Operating Range", "Correct Usage of the A-COSR Pressure Reducing Valve" and "Adjustment" sections be reviewed.

Troubleshooting Chart

Problem	Symptom	Cause	Remedy
The secondary pressure does not rise	The pressure does not increase	No air is being supplied or the inlet valve is closed	Check the valves and pipings
		The entrance to the screens or strainer is clogged	Clean or blow down
The secondary pressure cannot be adjusted or increases abnormally	Adjustment is difficult, and set pressure varies	The pilot screen is clogged	Clean
		There is insufficient air flow	Check the flow, replace the A-COSR if necessary
		The piston is clogged with dirt	Clean Check the piston ring
		The piston ring is worn	Replace with a new piston ring
		There is a build-up of dirt on the sliding surfaces of the piston, pilot or main valve	Clean
		Flow rate exceeds rated flow rate	Check the flow rate, replace with a larger size
		The adjustment screw has seized	Replace with a new adjustment screw

Troubleshooting continued on next page.

Troubleshooting Chart (continued)

Problem	Symptom	Cause	Remedy
The secondary pressure cannot be adjusted or increases abnormally (continued)	Adjustment is difficult, and set pressure varies (continued)	The small hole on the piston is clogged	Clean
		The diaphragm is distorted or damaged	Replace with a new diaphragm
		There is fluctuation in air consumption	Check the flow rate, replace the A-COSR if necessary
	Upon closing the valves on the secondary side, the secondary pressure abruptly rises as high as the primary pressure	The bypass valve is leaking	Check, clean, and replace with a new valve if necessary
		There is a build-up of dirt on or damage to the pilot valve seat or main valve seat	Clean Align Replace if necessary
Hunting or chattering occurs	Occurs at low air demand	It is being operated below the lower flow rate limit	Check the volume of air supply, replace with a smaller diameter valve
	Hunting never stops	There is too high a reduction ratio	Change within the specification range
		The selected model is inappropriate for the service conditions (specifications)	Check the model selection, replace the A-COSR if necessary
	Chattering never stops	Condensate is contained, or the trap is blocked	Check the trap Check the piping
		The selected model is inappropriate for the service conditions (specifications)	Check the model selection, replace the A-COSR if necessary

Product Warranty

1. Warranty Period
One year following product delivery.
2. Warranty Coverage
TLV CO., LTD. warrants this product to the original purchaser to be free from defective materials and workmanship. Under this warranty, the product will be repaired or replaced at our option, without charge for parts or labor.
3. This product warranty will not apply to cosmetic defects, nor to any product whose exterior has been damaged or defaced; nor does it apply in the following cases:
 - 1) Malfunctions due to improper installation, use, handling, etc., by other than TLV CO., LTD. authorized service representatives.
 - 2) Malfunctions due to dirt, scale, rust, etc.
 - 3) Malfunctions due to improper disassembly and reassembly, or inadequate inspection and maintenance by other TLV CO., LTD. authorized service representatives.
 - 4) Malfunctions due to disasters or forces of nature.
 - 5) Accidents or malfunctions due to any other cause beyond the control of TLV CO., LTD.
4. Under no circumstances will TLV CO., LTD. be liable for consequential economic loss damage or consequential damage to property.

* * * * *

For Service or Technical Assistance:

Contact your **TLV** representative or your regional **TLV** office.

Manufacturer

TLV CO., LTD.
881 Nagasuna, Noguchi
Kakogawa, Hyogo 675-8511 JAPAN
Tel: 81-(0)79-427-1800