



SEPARATOR FILTER

MODEL SF1 STAINLESS STEEL

FILTER WITH BUILT-IN CYCLONE SEPARATOR

Features

All stainless steel separator filter efficiently removes condensate and impurities from the flow medium. Suitable for applications requiring high-quality dry steam, and non-hazardous gas mains.

1. Built-in cyclone separator eliminates condensate, dirt and scale before filtering, extending filter maintenance cycle.
2. Separator achieves condensate separation efficiency as high as 98%.
3. Easy-to-clean 5-layer sintered wire mesh filter maintains extremely low pressure drop for extended periods.
4. Compact and lightweight.
5. Ferrule joint clamp facilitates cleaning and disassembling, reducing maintenance costs.

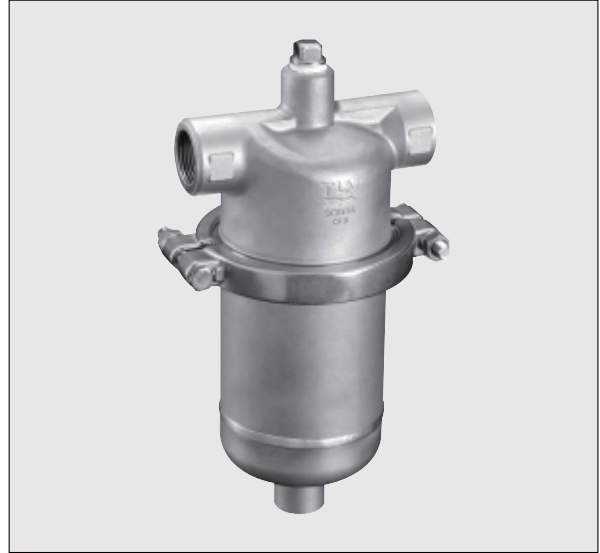

Specifications

Model		SF1		
Connection		Screwed	Socket Welded	Flanged
Size		DN 15, 20, 25, 40, 50		
Washing/Pressure Detection Port Connection		1/2" Screwed		
Condensate Outlet Connection		1/2" Screwed		
Maximum Operating Pressure (barg)	PMO	10		
Maximum Operating Temperature (°C)	TMO	185		
Filter Grade* (µm)		0.5, 2, 5		
Filter Construction		5-layer Sintered Wire Mesh		
Internal & External Finishing**		Acid Cleaning (lost-wax cast)		
Applicable Fluids***		Steam, Air		

* Consult TLV for other available filter grades ** Optional electro-polishing (lost-wax cast) available on request

1 bar = 0.1 MPa

*** Do not use for toxic, flammable or otherwise hazardous fluids

PRESSURE SHELL DESIGN CONDITIONS (NOT OPERATING CONDITIONS): Maximum Allowable Pressure (barg) PMA: 10
Maximum Allowable Temperature (°C) TMA: 185



To avoid abnormal operation, accidents or serious injury, DO NOT use this product outside of the specification range. Local regulations may restrict the use of this product to below the conditions quoted.

No.	Description	Material	DIN ¹⁾	ASTM/AISI ¹⁾
①	Body	Cast Stainl. Steel A351 Gr.CF8	1.4312	—
②	Separator	Cast Stainless Steel SCS13	1.4308	A351 Gr.CF8
③	Separator Body	15-25 mm Cast Stainl. Steel A351 Gr.CF8	1.4312	—
		40, 50 mm Cast Stainl. Steel A351 Gr.CF8/ Stainless Steel SUS304	1.4312/1.4301	—/AISI304
④	Separator Bottom	Cast Stainl. Steel A351 Gr.CF8	1.4312	—
⑤	Baffle	Stainless Steel SUS304	1.4301	AISI304
⑥	Filter	Stainless Steel SUS304/316/ 316L ²⁾	1.4301/1.4401/ 1.4404	AISI304/316/ 316L
⑦	Filter Gasket	High-performance Fluorine Resin	—	—
⑧	Body Clamp ³⁾	Cast Stainless Steel	1.4308	A351 Gr.CF8
⑨	Body Gasket	High-performance Fluorine Resin	—	—
⑩	Nameplate	Stainless Steel SUS304	1.4301	AISI304
⑪	Plug	Stainless Steel SUS304	1.4301	AISI304
⑫	Clamp Bolt ⁴⁾	Stainless Steel SUS304	1.4301	AISI304
⑬	Clamp Nut ⁴⁾	Stainless Steel SUS304	1.4301	AISI304
⑭	Spring Washer ⁴⁾	Stainless Steel SUS304	1.4301	AISI304
⑮	Flange ⁵⁾	Cast Stainl. Steel A351 Gr.CF8/ Stainless Steel SUS304 ²⁾	1.4312/1.4301	—/AISI304

¹⁾ Equivalent materials ²⁾ Material depends on filter grade or flange specifications
³⁾ Two-piece two-bolt clamp ⁴⁾ Not shown ⁵⁾ Shown on reverse

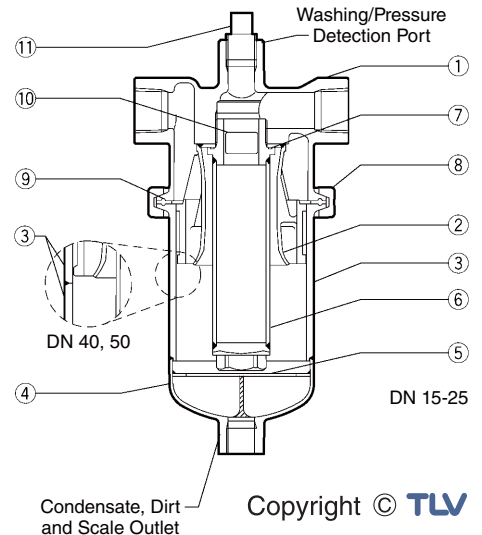

Copyright © TLV

Dimensions

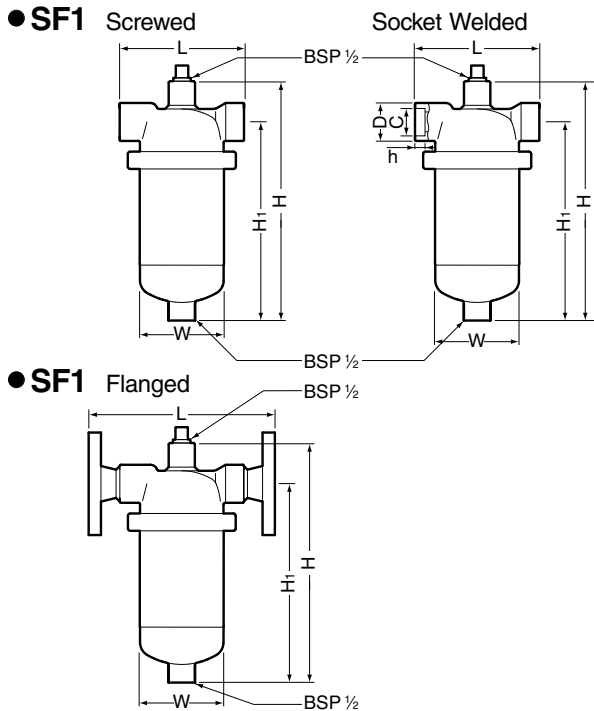

SF1 Screwed*/Socket Welded** (mm)

Size	DN	L	H	H ₁	φW	φD	φC	h	Weight (kg)
1/2"	15	130	255	210	89	36	21.8	13	4.5
3/4"	20								
1"	25	150	290	240	101	44	33.9	6.0	
1 1/2"	40	170	460	405	115	59	48.8	11	
2"	50	220	565	505	165	72	61.2	16	22

* BSP DIN 2999, other standards available
 ** ASME B16.11-2005, other standards available

SF1 Flanged (mm)

DN	L		H	H ₁	φW	Weight* (kg)
	DIN 2501	ASME Class				
	PN25/40	150RF				
15	202	191	255	210	89	6.2
20						6.8
25	232	227	290	240	101	8.7
40	252	251	460	405	115	16
50	310	331	565	505	165	28

Other standards available, but length and weigh may vary
 * Weight is for DIN PN 25/40

Steam Pressure Loss

● 0.5 μm Filter

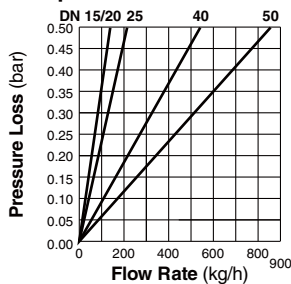

● 2 μm Filter

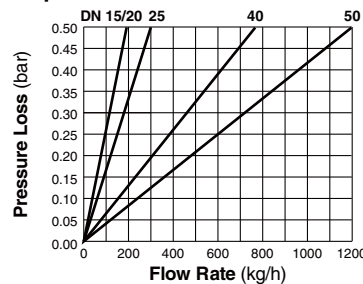

● 5 μm Filter

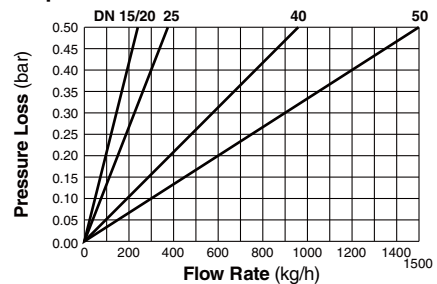

These pressure loss charts are based on a steam pressure of 1 barg. For other pressures, multiply the steam flow rate by the correction factor given in the table right. Use the result on the pressure loss chart.

Pressure (barg)	1	2	3	4	5	6	7	8	9	10
Flow Rate Correction Factor	1.0	0.83	0.72	0.65	0.60	0.56	0.52	0.49	0.47	0.45

Steam Flow Rate

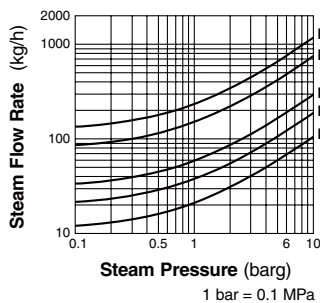

The chart to the left is used to determine the steam flow rate through the SF1 separator-filter. It is based on a steam velocity in the piping of 30 m/sec. For other velocities, calculate the flow rate as follows:

$$\text{Flow rate at } v \text{ m/sec} = \text{Flow Rate (at 30 m/sec)} \times \frac{v}{30}$$

It is recommended that steam velocities not exceed 30 m/s.

Note: For pressure loss and flow rate of air, contact TLV.

Manufacturer

ISO 9001/ISO 14001

TLV CO., LTD.
 Kakogawa, Japan

is approved by LRQA Ltd. to ISO 9001/14001

