

Standard Coupling
(supplied with actuator
weight 13.7 lbs/6.2 kg)

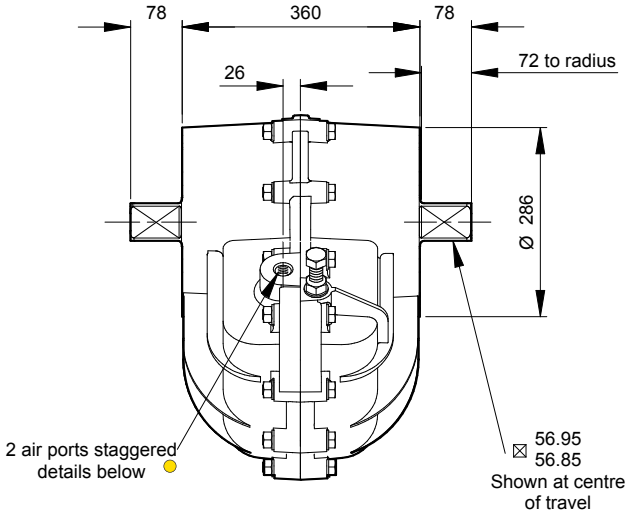

● Air Port/Mount Hole Details

Model	Air Ports	Mount Holes & Accessory Mount Holes
184-100	G ³ / ₄	4 x M30 x 50 deep on 226.3 PCD 4 x M5 x 8 deep
187-100	3/4 NPT	4 x 1 1/8 UNC x 2.00" deep on 8.91" PCD 4 x 10-24 UNC x 0.31" deep

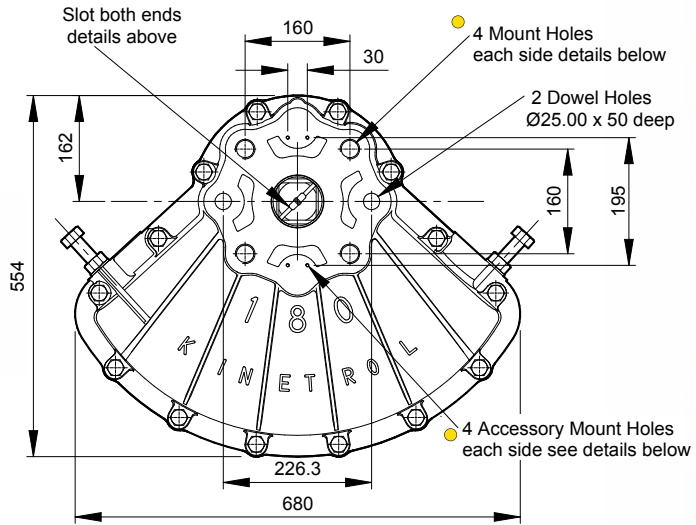

Specification

Output Torque

60000 lbf ins/6900 Nm
at 100 psi/7 bar

Angle of Travel (adjustable)

80° - 100°
(restricted travel
versions available)

Displaced Volume

1048 in³/17170 cm³

Finish

Epoxy stove enamel

Weight

157.4 lb/71.4 kg
(excluding coupling)

Options

- Fail safe spring return units - clockwise or counter clockwise see pages 5-7
- Limit switch boxes for open/close indication - various switches for hazardous areas see pages 9-12
- AP pneumatic positioner - full range of options see pages 17/18
- EL electropneumatic positioner - full range of options see pages 15/16
- Female drive and mounting details to DIN 3337 and ISO 5211 see page 50
- Spring to centre see page 24
- Code identification see page 62
- Torque outputs see pages 58-60
- See pages 49-52 for English dimensions and dimensions of spring options
- High Temperature / Low temperature options see page 50

For further information
see General Specification
on page 50

