

Model 20

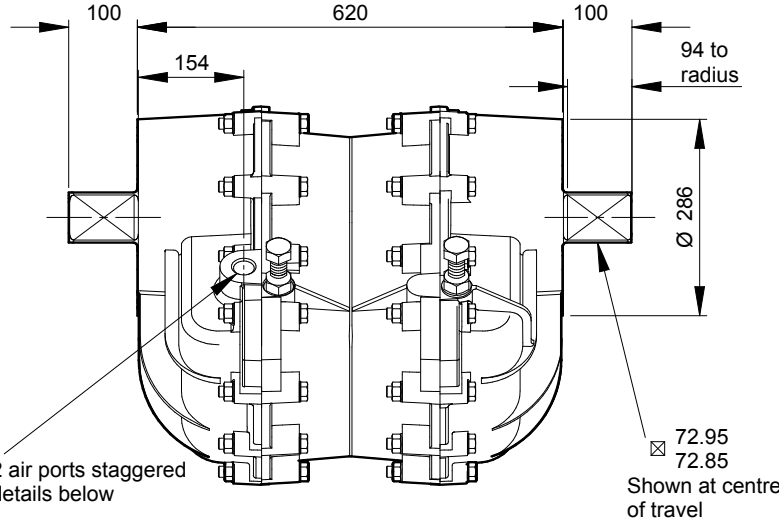

Standard Coupling
(supplied with actuator weight 34 lbs/15.4 kg)

Vane Slot detail both ends

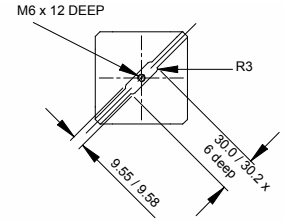
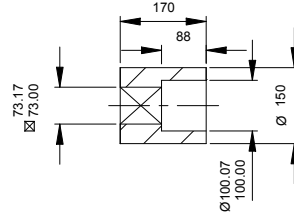

Specification

Output Torque

112000 lbf ins/12760 Nm
at 100 psi/7 bar

Angle of Travel (adjustable)

80° - 100°
(restricted travel versions available)

Displaced Volume

2034 in³/33350 cm³

Finish

Epoxy stove enamel

Weight

416.9 lb/195.6 kg
(excluding coupling)

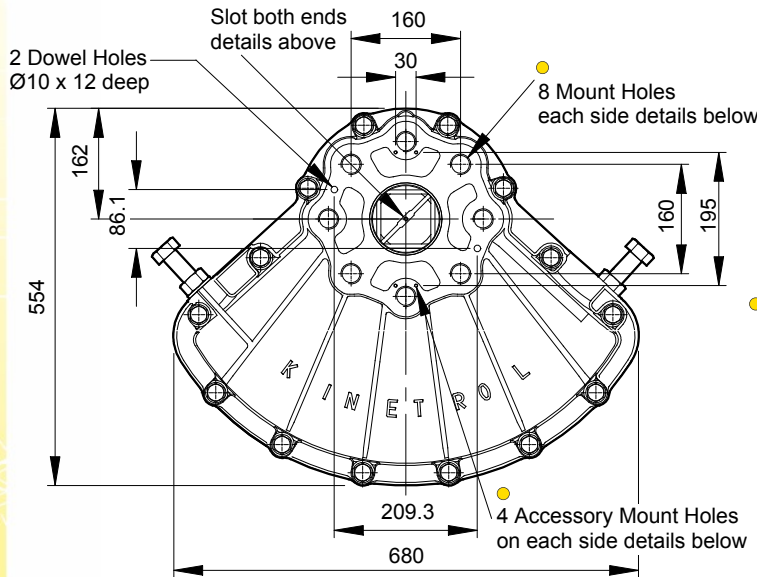

Air Port/Mount Hole Details

Model	Air Ports	Mount Holes & Accessory Mount Holes
204-100	G1	8 x M30 x 50 deep on 226.3 PCD 4 x M5 x 8 deep
207-100	1 NPT	8 x 1 1/8 UNC x 2.00" deep on 8.91" PCD 4 x 10-24 UNC x 0.31" deep

Options

- Fail safe spring return units - clockwise or counter clockwise see pages 5-7
- Female drive and mounting details to DIN 3337 and ISO 5211 see page 50
- Limit switch boxes for open/close indication - various switches for hazardous areas see pages 9-12
- Code identification see page 62
- AP pneumatic positioner - full range of options see pages 17/18
- Torque outputs see pages 58-60
- EL electropneumatic positioner - full range of options see pages 15/16
- See pages 49-52 for English dimensions and dimensions of spring options
- High Temperature / Low temperature options see page 50

For further information see General Specification on page 50.

